

MS619
0505
0004



MACNAUGHT®

The experts in fluid technology

Positive Displacement Flowmeters

———— M80 series instruction manual ————

(Refer to MS548 for Analogue Register Details)



M80 Mechanical meter • From serial No. DXXXX

To the owner

Please take a few minutes to read through this manual before installing and operating your meter. Always retain this manual for future reference. If you have any problems with the meter, refer to the maintenance and trouble shooting sections of this manual.

This manual contains connection and operating instructions for meters with Analogue Mechanical Displays. If you need further assistance, contact your

local representative or distributor for advice.

This Flow Meter has incorporated the oval rotor principal into its design. This has proven to be a reliable and highly accurate method of measuring flow. Exceptional repeatability and high accuracy over a wide range of fluid viscosities and flow rates are features of the oval rotor design. With low pressure drop and high pressure rating oval rotor flow meters are suitable for

both gravity and pump (in line) applications.

These Flow meters are available in Aluminium only. Standard rotors are made from Aluminium.

Important Information



PLEASE READ THIS INFORMATION CAREFULLY BEFORE USE!

Before use, confirm the fluid to be used is compatible with the meter (refer to the Industry fluid compatibility chart), or consult your local distributor or representative for advice.

To prevent damage from dirt or foreign

matter, it is recommended that a Y or Basket type 60 mesh strainer be installed as close as possible to the inlet side of the meter (if required contact your local distributor for further information).

Note: When a strainer is installed it should be regularly inspected and cleaned. Failure to keep the strainer clean will dramatically effect flow meter performance.

To prevent damage to the meter slowly fill the system with fluid (this will

prevent damage caused by air purge).

Note: Failure to do this could damage the meter.

For pump applications, turn off the pump at the end of each day.

Installation

1] It is recommended that when setting up pipework for meter installations a bypass line be included in the design. This provides the facility for a meter to be removed for maintenance without interrupting production. (See Fig.1)

(Refer to Fig.2 for correct installation) The register assembly may be orientated to suit the individual installation.

Note: Incorrect installation can cause premature wear of meter components.

2] Use thread sealant on all pipe threads. For flanged versions use appropriate companion flanges and gaskets.

3] For pump applications ensure pipe work has the appropriate working pressure rating to match the pressure output of the pump.

4] Install a wire mesh strainer (Y or basket type 60 mesh as close as possible to the inlet side of the meter.

5] Ensure that the meter is installed so that the flow of the liquid is in the direction of the arrows embossed on the meter body.

6] The meter can be installed in any orientation as long as the meter shafts are in a horizontal plane.

7] Do not over tighten meter connections.

8] **It is important that after initial installation you fill the line slowly, high speed air purge could cause damage to the rotors.**

9] Test the system for leaks.

10] Check the strainer for swarf or foreign material, after the first 200 litres check periodically, particularly if the flow rate decreases.

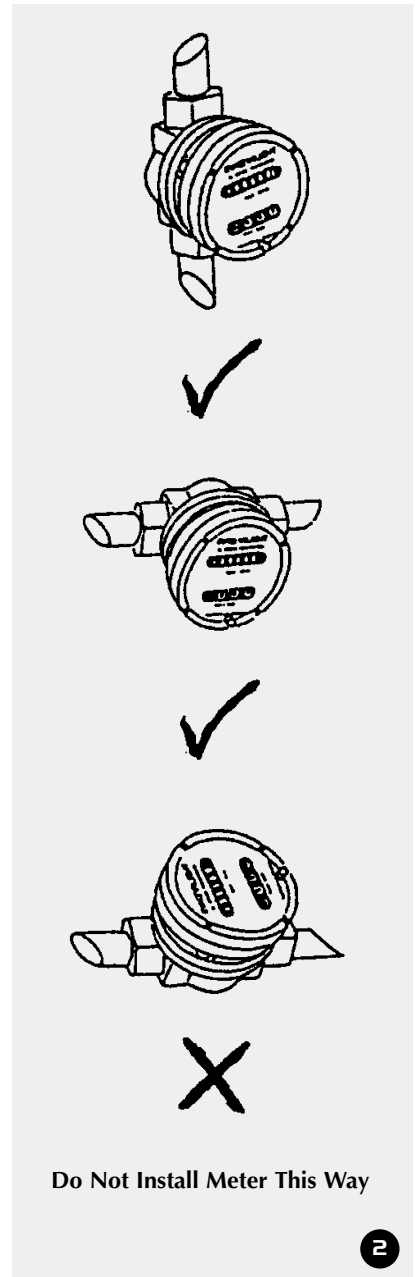
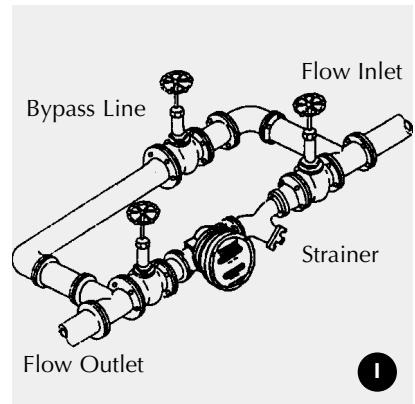

Operation

When fluid passes through the meter, rotors turn. The gear located on top of one of the rotors drives the mechanical registers gear train which provides an accurate readout.

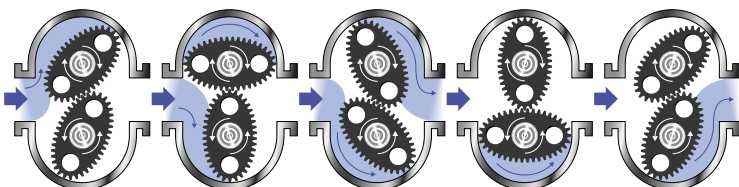

Service Instructions

Disassembly

Ensure that the fluid supply to the meter is disconnected, and the line pressure is released before disassembly. Refer to the exploded parts diagram for item numbers.

- 1] To remove the Analogue display refer to “Analogue Register Supplement” MS548.
- 2] Remove the six cover plate screws (Item 12) and remove the cover plate (Item 11).
- 3] Remove the eight meter cap screws (Item 5) and remove the meter cap (Item 4).
- 4] Remove rotors (Item 3).

Reassembly

- 1] Clean all components before reassembly.
- 2] Before reassembly check the condition of the rotors (Item 3). Replace if necessary.
- 3] Replace the rotor (with the gear) on the short shaft in the housing then place the 2nd rotor onto the shaft so as the rotors are at 90° to each other. (Refer Fig 3). Check rotor operation by turning either of the rotors. If the rotors are not in mesh correctly or do not move freely remove one of the rotors and replace it correctly at 90° to the other rotor. Recheck the operation of the rotors.
- 4] Inspect the gears (Item 6) in the

meter cap (Item 4) for wear. Replace if required, refer to spare parts listing.

- 5] Replace the o-ring (Item 2) into the groove in the meter cap, if the o-ring has been distorted or is damaged in any way replace it with a new part.
- 6] Replace the meter cap, making sure the locating pins line up with the holes in the meter cap and the gear on the rotor meshes correctly with the gear in the meter cap (Item 4). Insert the allen screws (Item 5) and tighten in the sequence 1, 6, 2, 5, 3, 7, 4, 8.
- 7] Inspect the Drive Dog, o-ring (Item 10), and output gear (Item 7) for wear or damage. (Replace faulty components if necessary).
- 8] Replacement of output shaft, bush and seal.

Disassembly

- a. Remove the Drive Dog.
- b. Remove the circlip and push out the output shaft assembly, including washer (Items 7, 8, 9).
- c. Remove the seal.
- d. Carefully press out the output shaft bush (If required).

Assembly

- a. Carefully press the new output shaft bush into place (Use Loctite Primer 747, as per instructions, followed by sealant Loctite 680).
- b. Insert a new seal into the groove of the output shaft bush.
- c. Replace the output gear and washer and replace the circlip to

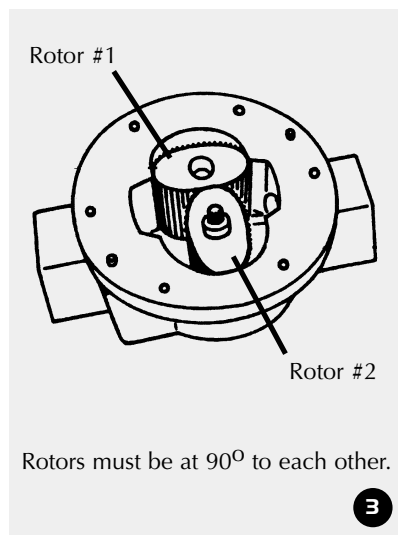

lock the output gear shaft into place.
d. Replace the Drive Dog (Item 13) and tighten the grub screw onto flat face of shaft.

- 9] Place the o-ring (Item 10) into the groove in the cover plate (Replace the o-ring seal if required).
- 10] Place the cover plate onto the meter. Replace the cover plate screws and tighten the six cap head screws (Item 12) firmly.
- 11] To install the Analogue Register refer to “Analogue Register Supplement” MS548.
- 12] Test the meter by turning the rotors with a finger or by applying low air pressure to one end of the meter, before returning meter to the line.

Meter Trouble Shooting

TROUBLE SHOOTING GUIDE		
TROUBLE	CAUSE	REMEDY
Fluid will not flow through meter	<ul style="list-style-type: none"> a] Foreign matter blocking rotors b] Line strainer blocked c] Damaged rotors d] Meter connections over tightened e] Fluid is too viscous 	<ul style="list-style-type: none"> a] Dismantle meter, clean rotors (Strainer must be fitted in line) b] Clean strainer c] Replace rotors (Strainer must be fitted in line) d] Re-adjust connections e] See specifications for maximum viscosity
Reduced flow through the meter	<ul style="list-style-type: none"> a] Strainer is partially blocked b] Fluid is too viscous 	<ul style="list-style-type: none"> a] Clean strainer b] See specifications for maximum viscosity
Meter reading inaccurate	<ul style="list-style-type: none"> a] Fluid flow rate is too high or too low b] Fluid is too viscous c] Excess wear caused by incorrect installation 	<ul style="list-style-type: none"> a] See "specifications" for minimum and maximum flow rates b] Bleed air from system c] Check meter body and rotors. Replace as required. Refer to installation instructions
Fluid flows but no reading on meter	<ul style="list-style-type: none"> a] Drive Dog is loose on shaft b] Rotor drive gear is damaged c] Transmission gears damaged d] Register gears damaged 	<ul style="list-style-type: none"> a] Tighten grub screws b] Replace rotor c] Replace gears d] Replace register assembly
Fluid leaks into register	<ul style="list-style-type: none"> a] Seal worn or damaged on the cover plate 	<ul style="list-style-type: none"> a] Replace seal (Check seal compatibility with fluid)

Meter Parts Listing

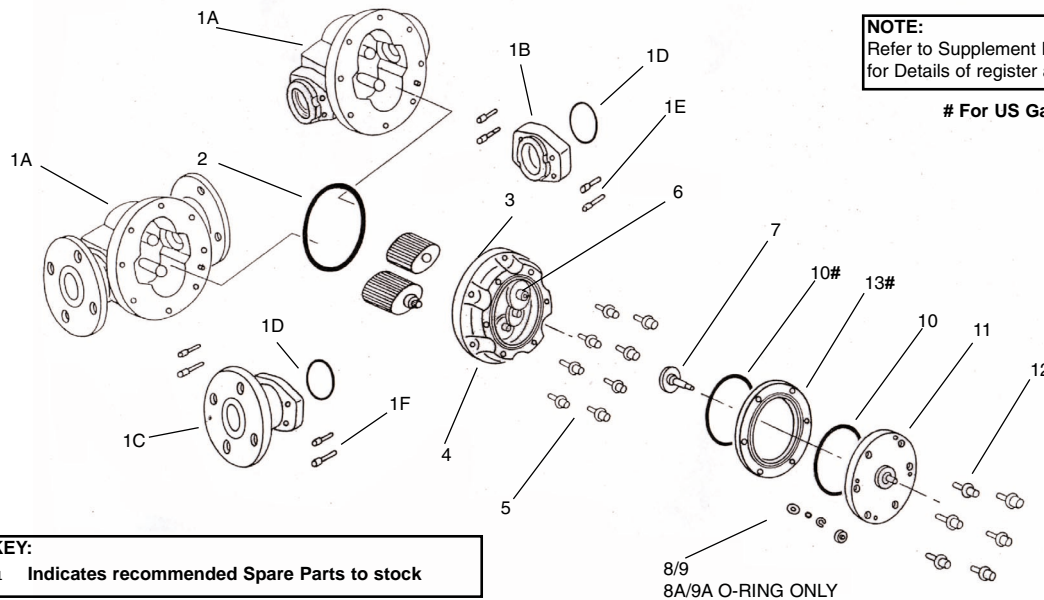

NOTE:
Refer to Supplement Instruction Sheet
for Details of register assembly.

For US Gallon Model Only

KEY:

u Indicates recommended Spare Parts to stock

**NOTE: SPARE PARTS FOR D SERIES METERS FITTED
WITH ROLLER BEARINGS**

Item No.	No. Off.	Rec. Parts	Part or Set (Order from this column only)	Part Description
1A	1		MS688S	Meter Body Module (Aluminium)
1B	2		MS578S	3" BSP Flange (Aluminium)
1B	2		MS578NS	3" NPT Flange (Aluminium)
1C	2		MS579S	3" ANSI-150lb Flange (Aluminium)
1C	2		MS579DS	3" DIN16 Flange (Aluminium)
1C	2		MS579JS	3" JIS-10K Flange (Aluminium)
1D	2	u	BS237S	O-ring (NBR)
1D	2	u	BS237ES	O-ring (EPDM)
1D	2	u	BS237TES	O-ring (Teflon)
1D	2	u	BS237VS	O-ring (Viton)
1E	4	u	MS585S	Bolt Set (To suit 1B only)
1F	4	u	MS528S	Bolt Set (To suit 1C only)
2	1	u	BS262S	O-ring (NBR)
2	1	u	BS262ES	O-ring (EPDM)
2	1	u	BS262TES	O-ring (Teflon)
2	1	u	BS262VS	O-ring (Viton)
3	1	u	MS692MS	Rotors (Aluminium)
4	1		MS599S	Meter Cap Litres (Aluminium) incl. Gear set
4	1		MS598S	Meter Cap US Gallon (Aluminium) incl. Gear set
5	8		MS243S	Meter Cap Screws (Standard)
6	1	u	MS616S	Complete Gear Set - Litres
6	1	u	MS625S	Complete Gear Set - US Gallons
7	1	u	MS97S	Output Gear and Shaft Assembly
8	1	u	MS78S	Cover Plate Seal/Bush set Standard
9A	1		N7-007S	Standard O-ring (NBR)
10	2		BS145S	O-ring (NBR)
10	2		BS145ES	O-ring (EPDM)
10	2		BS145TES	O-ring (Teflon)
10	2		BS145VS	O-ring (Viton)
11	1		MS327S	Coverplate (Aluminium) includes bush
12	1		MS312S	Coverplate Screws
13	1		MS423	Spacer Ring (US Gallon Models Only)

Meter Dimensions

Mechanical Meter Dimensions

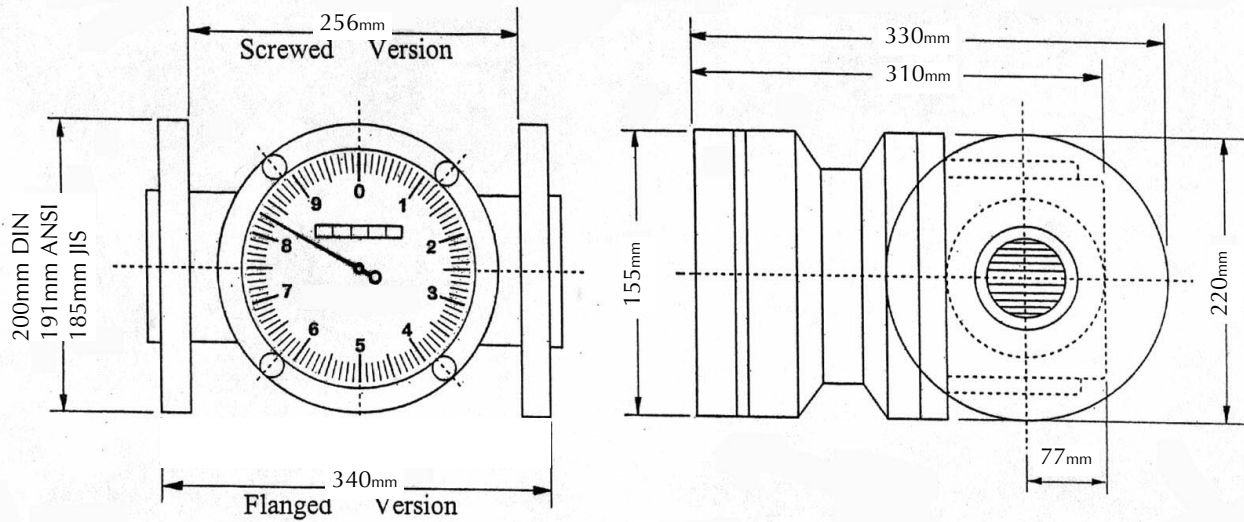

Meter Specifications

Flow Ranges

(Litres per minute/US Gallons per minute)

Above 5 Centipoise 70 to 700/ 18.5 to 185

Accuracy of Reading +/- 1%

Maximum Viscosity 1000 Centipoise

Maximum Operating Pressure 1200 kPa / 175 PSI / 12 BAR

Maximum Operating Temperature 80°C / 176°F

Warranty

Macnaught Industries ('Macnaught') warrants that the Products will be free from any defects caused by faulty material or workmanship for a period of twelve (12) months from the date of sale of the Products to the enduser (the 'Warranty Period') PROVIDED THAT, during the Warranty Period:

1. Macnaught receives notice setting out full details of any defect in any product and details of the time and place of purchase of the Product: and

2. the enduser, at its own cost returns the Product to the nearest authorised Macnaught Service Centre.



Macnaught shall, as its option repair or replace any Product found defective by its inspection or refund the price paid by the enduser for that Product.

Macnaught's liability and the enduser's rights under this warranty shall be limited to such repair, replacement or refund and, in particular, shall not extend to any direct, special, indirect

or consequential damage or losses of any nature.

Note:

This warranty does not form part of, nor does it constitute, a contract between Macnaught and the enduser. It is additional to any warranty given by the seller of the Products and does not exclude, limit, restrict or modify the rights and remedies conferred upon the enduser, or the liabilities imposed on the seller, by any statute or other laws in respect of the sale of the Product.



www.bellflowsystems.co.uk