



MS489
0801
0002

MACNAUGHT®

The experts in fluid technology

Positive Displacement Flowmeters

M4 series instruction manual



M4 Mechanical meter • From serial No. CXXXX

To the owner

Thank you for purchasing a Macnaught M Series Flow Meter. Please take a few minutes to read through this manual before installing and operating your meter. If you have any problems with the meter, refer to the maintenance and trouble shooting sections of this manual.

This manual contains connection and operating instructions for the M4 Series meters with mechanical displays. If you need further assistance, contact your local Macnaught representative or

contact Macnaught by telephone or fax for advice.

The Macnaught M Series Flow Meter has incorporated the oval rotor principal into its design. This has proven to be a reliable and highly accurate method of measuring flow. Exceptional repeatability and high accuracy over a wide range of fluid viscosities and flow rates are features of the M Series flow meter design. The low pressure drop and high pressure rating means the M Series flow meter is

suitable for both gravity and pump (in line) applications.

The Macnaught M Series flow meters are available in either aluminium or 316 stainless steel. Standard rotors are made from PPS.

The M4 Series mechanical displays have a resettable batch totaliser and non-resettable accumulative totaliser.

Important Information



PLEASE READ THIS INFORMATION CAREFULLY BEFORE USE!

Before use, confirm the fluid to be used is compatible with the meter (refer to the Macnaught fluid compatibility chart), or consult your local Macnaught representative for advice.

This meter will handle particle sizes up to 0.25mm/0.011".

To prevent damage from dirt or foreign matter, Macnaught recommends a Y or Basket type 60 mesh strainer be installed as close as possible to the inlet side of the meter (if required contact Macnaught for further

information).

Note: When a strainer is installed it should be regularly inspected and cleaned. Failure to keep the strainer clean will dramatically effect flow meter performance.

To prevent damage to the meter slowly fill the system with fluid (this will prevent damage caused by air purge).

Note: Failure to do this could damage the meter.

For pump applications, turn off the pump at the end of each day.

Installation

1] Macnaught recommends that when setting up pipework for meter installations a bypass line be included in the design. This provides the facility for a meter to be removed for maintenance without interrupting production. (See Fig.1)

2] Use thread sealant on all pipe threads.

3] For pump applications ensure pipe work has the appropriate working pressure rating to match the pressure output of the pump. The maximum working pressures are;

1/2" aluminium or stainless steel series 3450kPa/34.5Bar/500PSI.

4] Install a wire mesh strainer (Y or basket type 60 mesh as close as possible to the inlet side of the meter.

5] Ensure that the meter is installed so that the flow of the liquid is in the direction of the arrows embossed on the meter body.

6] The meter can be installed in any orientation as long as the meter

shafts are in a horizontal plane. (Refer to Fig.2 for correct installation) The register assembly may be orientated to suit the individual installation.

Note: Incorrect installation can cause premature wear of meter components.

7] Do not over tighten meter connections.

8] **It is important that after initial installation you fill the line slowly, high speed air purge could cause damage to the rotors.**

9] Test the system for leaks.

10] Check the strainer for swarf or foreign material, after the first 200 litres check periodically, particularly if the flow rate decreases.

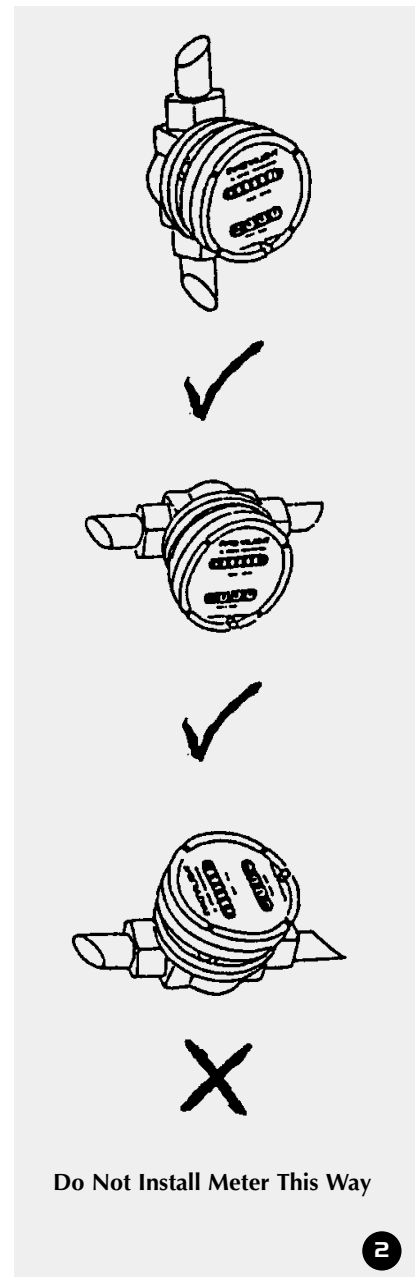
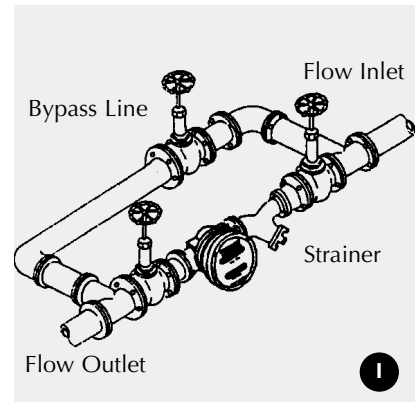

Operation

When fluid passes through the meter, accurate readout. rotors turn. The gear located on top of one of the rotors drives the mechanical registers gear train which provides an

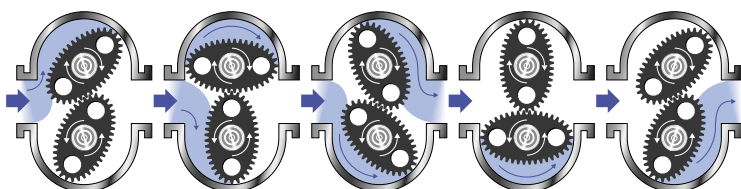

Service Instructions

Disassembly

Ensure that the fluid supply to the meter is disconnected, and the line pressure is released before disassembly. Refer to the exploded parts diagram on page 5 for item numbers.

- 1] Remove the four screws (Item 17) located on the face of the register. Then remove the face plate cover including register assembly.
- 2] Remove the four register mounting screws (Item 15). Then remove the lower half of the register housing.
- 3] Remove the six cover plate screws (Item 12) and remove the cover plate (Item 11).
- 4] Remove the four meter cap screws (Item 5) and remove the meter cap (Item 4).
- 5] Remove rotors (Item 3).

Reassembly

- 1] Clean all components before reassembly.
- 2] Before reassembly check the condition of the rotors (Item 3). Replace if necessary.
- 3] Replace the rotor (with the gear) on the short shaft in the housing then place the 2nd rotor onto the shaft so as the rotors are at 90° to each other. (Refer Fig 3). Check rotor operation by turning either of the rotors. If the rotors are not in mesh correctly or do not move freely remove one of the rotors and

replace it correctly at 90° to the other rotor. Recheck the operation of the rotors.

- 4] Inspect the gears (Item 6) in the meter cap (Item 4) for wear. (Replace if required, refer to spare parts on page 6 & 7).
- 5] Replace the o-ring (Item 2) into the groove in the meter cap, if the o-ring has been distorted or is damaged in any way replace it with a new part.
- 6] Replace the meter cap, making sure the meter cap and the gear on the rotor meshes correctly with the gear in the meter cap (Item 4). Insert the allen screws (Item 5) and tighten in the sequence 1, 4, 2, & 3.
- 7] Inspect the bevel gear (Item 13), o-ring (Item 10), and output gear (Item 7) for wear or damage. (Replace faulty components if necessary).
- 8] Replacement of output shaft, bush and seal.

Disassembly of output shaft

- a. Remove the bevel gear.
- b. Remove the circlip and push out the output shaft assembly, including washer.
- c. Remove the seal.
- d. Carefully press out the output shaft bush (If required).

Assembly of output shaft

- a. Carefully press the new output shaft bush into place (Use Loctite Primer 7471, as per instructions, followed by sealant Loctite 262).

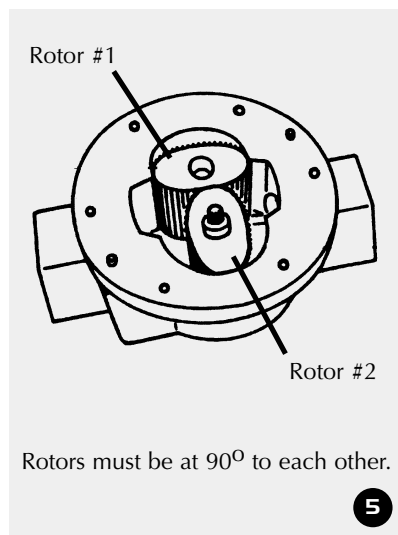

- b. Insert a new seal into the groove of the output shaft bush.
- c. Replace the output gear and washer and replace the circlip to lock the output gear shaft into place.
- d. Replace the bevel gear (Item 13) and tighten the grub screw onto flat face of shaft.

- 9] Place the o-ring (Item 10) into the groove in the meter cap (Replace the o-ring seal if required).
- 10] Place the cover plate onto the meter. Replace the cover plate screws and tighten the six cap head screws (Item 12) firmly.
- 11] Place the lower cover plate of the register into position. Replace the four screws (Item 15) and tighten.
- 12] Position the register correctly on top of the lower register cover. Replace the four screws (Item 17) and tighten.
- 13] Test the meter by turning the rotors with a finger or by applying low air pressure (No more than a good breath) to one end of the meter, before returning meter to the line.

Meter Trouble Shooting

TROUBLE SHOOTING GUIDE		
TROUBLE	CAUSE	REMEDY
Fluid will not flow through meter	<ul style="list-style-type: none"> a] Foreign matter blocking rotors b] Line strainer blocked c] Damaged rotors d] Meter connections over tightened e] Fluid is too viscous 	<ul style="list-style-type: none"> a] Dismantle meter, clean rotors (Strainer must be fitted in line) b] Clean strainer c] Replace rotors (Strainer must be fitted in line) d] Re-adjust connections e] See specifications for maximum viscosity
Reduced flow through the meter	<ul style="list-style-type: none"> a] Strainer is partially blocked b] Fluid is too viscous 	<ul style="list-style-type: none"> a] Clean strainer b] See specifications for maximum viscosity
Meter reading inaccurate	<ul style="list-style-type: none"> a] Fluid flow rate is too high or too low b] Fluid is too viscous c] Excess wear caused by incorrect installation 	<ul style="list-style-type: none"> a] See "specifications" for minimum and maximum flow rates b] Bleed air from system c] Check meter body and rotors. Replace as required. Refer to installation instructions
Fluid flows but no reading on meter	<ul style="list-style-type: none"> a] Bevel gear is loose on shaft b] Rotor drive gear is damaged c] Transmission gears damaged d] Register gears damaged 	<ul style="list-style-type: none"> a] Tighten grub screws b] Replace rotor c] Replace gears d] Replace register assembly
Fluid leaks into register	<ul style="list-style-type: none"> a] Seal worn or damaged on the cover plate 	<ul style="list-style-type: none"> a] Replace seal (Check seal compatibility with fluid)

Meter Parts Listing

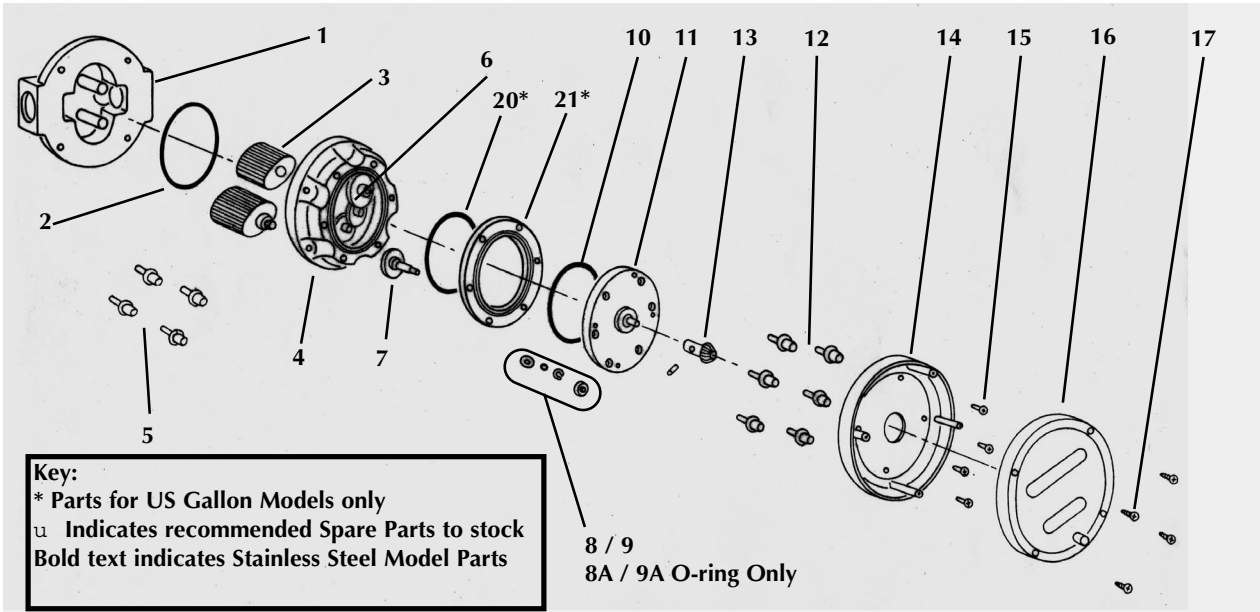

Item No.	No. Off.	Rec. Parts	Part or Set (Order from this column only)	Part Description
1	1		MS298B	Meter Body 1/2" BSP (Aluminium)
1	1		MS298N	Meter Body 1/2" NPT (Aluminium)
1	1		MS337B	Meter Body 1/2" BSP (Stainless Steel)
1	1		MS337N	Meter Body 1/2" NPT (Stainless Steel)
2	1	u	BS145S	"O" Ring (NBR)
2	1	u	BS145ES	"O" Ring (EPDM)
2	1	u	BS145TES	"O" Ring (Teflon)
2	1	u	BS145VS	"O" Ring (Viton)
3	2	u	MS342MS	Rotors PPS (Polyphenylene Sulfide Resins)
3	2	u	MS342MTS	High Temperature Rotors (PPS)
3	2	u	MS342MHS	High Viscosity Rotors (PPS)
3	2	u	MS342MHTS	High Viscosity/High Temperature Rotors (PPS)
4	1		MS544S	Meter Cap Liters (Aluminium)
4	1		MS547S	Meter Cap US Gallons (Aluminium)
4	1		MS545S	Meter Cap Liters (Stainless Steel)
4	1		MS546S	Meter Cap US Gallons (Stainless Steel)
5	4	u	MS346S	Meter Cap Screws (Standard)
5	4	u	MS350S	Meter Cap Screws (Stainless Steel)
6	1	u	MS539S	Complete Gear Set - Liters
6	1	u	MS541S	Complete Gear Set - US Gallons
7	1	u	MS77S	Output Gear & Shaft Assembly
8	1	u	MS78S	Coverplate Seal/Bush Set Standard
8A	1	u	OR42CS	Solvent o-ring (Perfluoro Elastomer)
9	1	u	MS78C	Coverplate Seal/Bush Set Solvent
9A	1	u	N7-007S	Standard o-ring (NBR)
9A	1	u	E7-007S	O-ring (EPDM)
9A	1	u	V7-007S	O-ring (Viton)
10	1	u	BS145S	O-ring (NBR)
10	1	u	BS145ES	O-ring (EPDM)
10	1	u	BS145TES	O-ring (Teflon)
10	1	u	BS145VS	O-ring (Viton)

Meter Parts Listing

Item No.	No. Off.	Rec. Parts	Part or Set (Order from this column only)	Part Description
11	1		MS99S	Coverplate (Aluminium) includes bush
11	1		MS99-1S	Coverplate (Stainless Steel) includes bush
12	6	u	MS312S	Coverplate Screws - Litre Model
12	6	u	MS313S	Coverplate Screws (Stainless Steel) Litre Model
12	6	u	MS419S	Coverplate Screws - US Gallon Model
12	6	u	MS420S	Coverplate Screws (Stainless Steel) US Gallon Model
13	1	u	MS83S	Bevel Gear Set
14	1		MS140S	Bottom Register Coverplate
15	4	u	MS111S	Mounting Screws
16	1	u	MS141M4S	Register Assembly with Coverplate - Liters
16	1	u	MS141US	Register Assembly with Coverplate - US Gallons
17	4	u	MS129S	Register Body Screws
20	1	u	BS145S	O-Ring (NBR)
20	1	u	BS145ES	O-Ring (EPDM) } US Gallon Model Only
20	1	u	BS145TES	O-Ring (Teflon)
20	1	u	BS145VS	O-Ring (Viton)
21	1	u	MS423S	Spacer Ring (Aluminium) US Gallon Model Only
21	1	u	MS423-1S	Spacer Ring (Stainless Steel) US Gallon Model Only

Meter Dimensions

M4 Mechanical Meter Dimensions

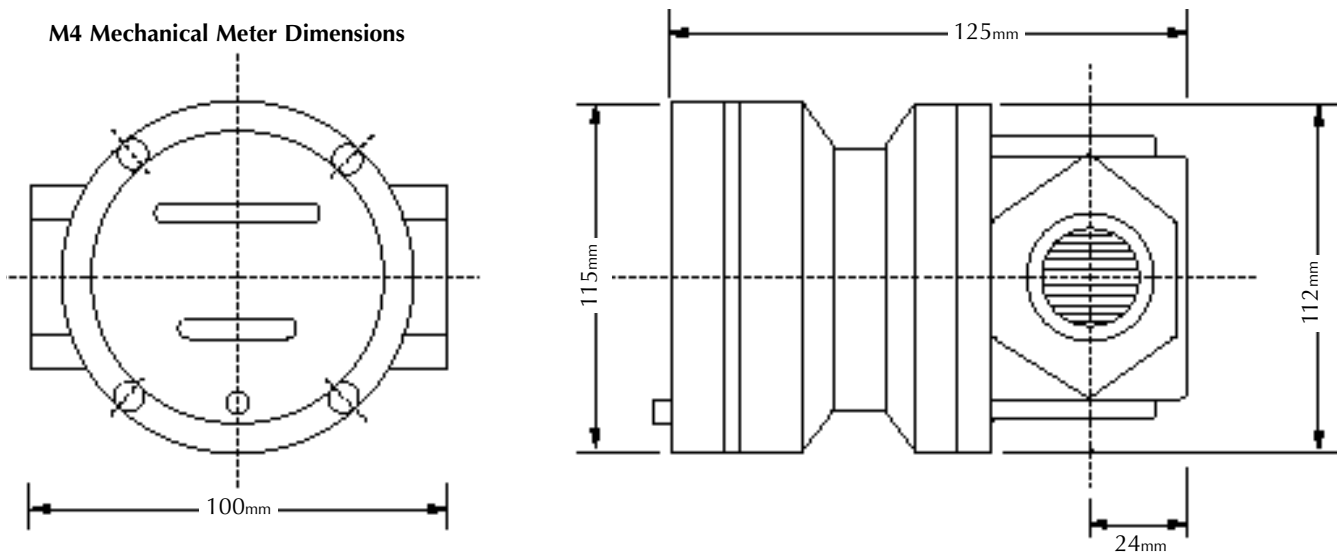

Meter Specifications

Flow Ranges

(Litres per minute/US Gallons per minute)

Above 5 Centipoise 1 to 30/ 0.26 to 8

Below 5 Centipoise 3 to 25/ 0.8 to 6.6

Accuracy of Reading +/- 1%

Maximum Viscosity 1000 Centipoise

Maximum Operating Pressure 3450 kPa / 500 PSI / 34.5 BAR

Maximum Operating Temperature 80°C / 176°F

Warranty

Macnaught warrants that the Products will be free from any defects caused by faulty material or workmanship for a period of twelve (12) months from the date of sale of the Products to the enduser (the 'Warranty Period') PROVIDED THAT, during the Warranty Period:

1. Macnaught receives notice setting out full details of any defect in any product and details of the time and place of purchase of the Product: and

2. the enduser, at its own cost returns the Product to the nearest authorised Macnaught Service Centre.



Macnaught shall, as its option repair or replace any Product found defective by its inspection or refund the price paid by the enduser for that Product.

Macnaught's liability and the enduser's rights under this warranty shall be limited to such repair, replacement or refund and, in particular, shall not

extend to any direct, special, indirect or consequential damage or losses of any nature.

Note:

This warranty does not form part of, nor does it constitute, a contract between Macnaught and the enduser. It is additional to any warranty given by the seller of the Products and does not exclude, limit, restrict or modify the rights and remedies conferred upon the enduser, or the liabilities imposed on the seller, by any statute or other laws in respect of the sale of the Product.



Quality Endorsed Company

www.bellflowsystems.co.uk