



MS489FA
1002
0001

MACNAUGHT®

The experts in fluid technology

Positive Displacement Flowmeters — M4 Encoder series instruction manual —



M4 Encoder series meter • From serial No. CXXXX

To the owner

Please take a few minutes to read through this manual before installing and operating your meter. If you have any problems with the meter, refer to the maintenance and trouble shooting sections of this manual.

This manual contains connection and operating instructions for Encoder Series meters. If you need further assistance, contact your local representative or distributor.

This Flow Meter has incorporated the Oval rotor principal into its design. This has proven to be a reliable and highly accurate method of measuring flow. Exceptional repeatability and high accuracy over a wide range of fluid viscosities and flow rates are features of the Oval rotor design. The low pressure drop and high pressure rating means Oval rotor flow meters are suitable for both gravity and pump (in line) applications.

Flow meters are available in either aluminium or 316 stainless steel. Standard rotors are made from PPS (Polyphenylene Sulfide Resins) with optional 316 stainless steel rotors available for both stainless steel and aluminium models.

Important Information



PLEASE READ THIS INFORMATION CAREFULLY BEFORE USE!

Before use, confirm the fluid to be used is compatible with the meter. Refer to industry fluid compatibility charts or consult your local representative for advice.

To prevent damage from dirt or foreign matter it is recommended that a Y or Basket type 60 mesh strainer be installed as close as possible to the

inlet side of the meter. Contact your local representative for advice.

Note: When a strainer is installed it should be regularly inspected and cleaned. Failure to keep the strainer clean will dramatically effect flow meter performance.

Note: To prevent damage caused by air purge slowly fill the meter with fluid.

To reduce pressure build up turn off the pump at the end of each day.

When maintenance to any part of the meter is required, the meter must be isolated and the line pressure reduced.

Installation

1] It is recommended that when setting up pipework for meter installations a bypass line be included in the design. This provides the facility for a meter to be removed for maintenance without interrupting production. (See Fig.1)

2] Use thread sealant on all pipe threads. For flanged versions appropriate companion flanges and gaskets are required.

3] For pump applications ensure pipe work has the appropriate working pressure rating to match the pressure output of the pump.

4] Install a wire mesh strainer (Y or basket type) 60 mesh as close as possible to the inlet side of the meter.

5] Ensure that the meter is installed so that the flow of the liquid is in the direction of the arrows embossed on the meter body.

6] The meter can be installed in any orientation as long as the meter shafts are in a horizontal plane. (Refer to Fig.2 for correct

installation)

Note: Incorrect installation can cause premature wear of meter components.

7] Do not over tighten meter connections.

8] It is important that after initial installation you fill the line slowly, high speed air purge could cause damage to the rotors.

9] Test the system for leaks.

10] Check the strainer for swarf or foreign material, after the first 200 litres check periodically, particularly if the flow rate decreases.

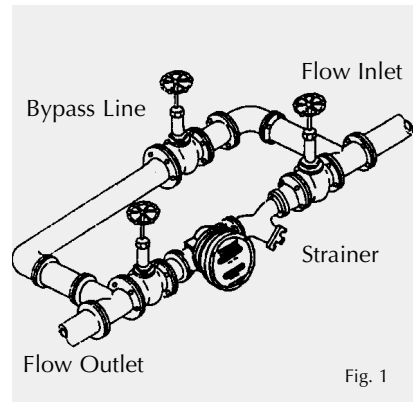

Fig. 1

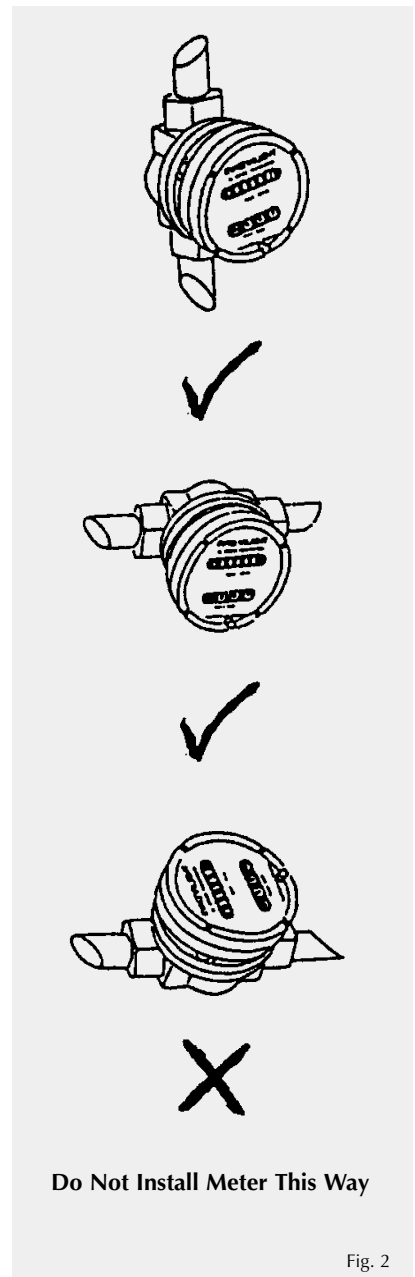
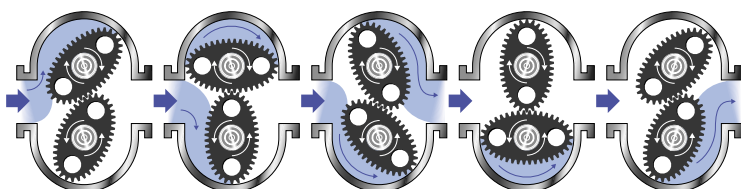

Fig. 2

Operation

When fluid passes through the meter, rotors turn. The gear located on top of one of the rotors drives the mechanical registers gear train which then drives the encoder giving a pulse output.



Service Instructions

Meter Disassembly

Ensure that the fluid supply to the meter is disconnected, and the line pressure is released before disassembly. Refer to the exploded parts diagram, Figure 5, for item numbers.

- 1] Remove the four screws (Item 16) located on the face of the Encoder adaptor. Then remove the Encoder adaptor.
- 2] Remove the six cover plate screws (Item 12) and remove the cover plate (Item 11).
- 3] Remove the four meter cap screws (Item 5) and remove the meter cap (Item 4).
- 4] Remove rotors (Item 3).

Meter Reassembly

- 1] Clean all components before reassembly.
- 2] Before reassembly check the condition of the rotors (Item 3). Replace if necessary.
- 3] Replace the rotor (with the gear) on the short shaft in the housing then place the 2nd rotor onto the shaft so as the rotors are at 90° to each other. (Refer Fig 3). Check rotor operation by turning either of the rotors. If the rotors are not in mesh correctly or do not move freely remove one of the rotors and replace it correctly at 90° to the other rotor. Recheck the operation of the rotors.

- 4] Inspect the gears (Item 6) in the meter cap (Item 4) for wear. (Replace if required, refer to spare parts on page 5).
- 5] Replace the o-ring (Item 2) into the groove in the meter cap, if the o-ring has been distorted or is damaged in any way replace it with a new part.
- 6] Replace the meter cap, ensuring the gear on the rotor meshes correctly with the gear in the meter cap (Item 4). Insert the meter cap screws (Item 5) and tighten in the sequence 1, 4, 2, & 3.
- 7] Inspect the drive dog (Item 13), o-ring (Item 10), and output gear (Item 7) for wear or damage. (Replace faulty components if necessary).

Output shaft Seal Replacement

Disassembly

- a. Remove the drive dog (Item 13).
- b. Remove the circlip and push out the output shaft assembly, including washer.
- c. Remove the seal.
- d. Carefully press out the output shaft bush (If required).

Assembly

- a. Carefully press the new output shaft bush into place (Use Loctite Primer 7471, as per instructions, followed by sealant Loctite 680).
- b. Insert a new seal into the groove of the output shaft bush.
- c. Replace the output gear and washer and replace the circlip to lock the output gear shaft into place.
- d. Replace the drive dog (Item 13)

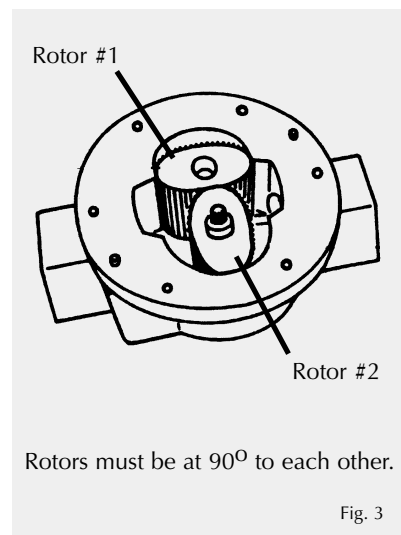

and tighten the grub screw onto flat face of shaft.

- 9] Place the o-ring (Item 10) into the groove in the meter cap (Item 4) (Replace the o-ring seal if required).
- 10] Place the cover plate onto the meter. Replace the meter cap screws and tighten the six cap head screws (Item 12) firmly.
- 11] Place the Encoder adaptor into position. Making sure the drive dogs engage correctly with each other. Replace the four screws (Item 16) and tighten.
- 12] Test the meter by turning the rotors with a finger or by applying low air pressure (No more than a good breath) to one end of the meter, before returning meter to the line.

Meter Trouble Shooting

TROUBLE SHOOTING GUIDE		
TROUBLE	CAUSE	REMEDY
Fluid will not flow through meter	<ul style="list-style-type: none"> a] Foreign matter blocking rotors b] Line strainer blocked c] Damaged rotors d] Meter connections over tightened e] Fluid is too viscous 	<ul style="list-style-type: none"> a] Dismantle meter, clean rotors (Strainer must be fitted in line) b] Clean strainer c] Replace rotors (Strainer must be fitted in line) d] Re-adjust connections e] See specifications for maximum viscosity
Reduced flow through the meter	<ul style="list-style-type: none"> a] Strainer is partially blocked b] Fluid is too viscous 	<ul style="list-style-type: none"> a] Clean strainer b] See specifications for maximum viscosity
Meter reading inaccurate	<ul style="list-style-type: none"> a] Fluid flow rate is too high or too low b] Fluid is too viscous c] Excess wear caused by incorrect installation 	<ul style="list-style-type: none"> a] See "specifications" for minimum and maximum flow rates b] Bleed air from system c] Check meter body and rotors. Replace as required. Refer to installation instructions
Fluid flows but no reading on meter	<ul style="list-style-type: none"> a] Drive Dog is loose on shaft b] Rotor drive gear is damaged c] Transmission gears damaged d] Encoder is damaged 	<ul style="list-style-type: none"> a] Tighten grub screws b] Replace rotor c] Replace gears d] Replace Encoder assembly
Fluid leaks from Encoder adaptor	<ul style="list-style-type: none"> a] Seal worn or damaged on the cover plate 	<ul style="list-style-type: none"> a] Replace seal (Check seal compatibility with fluid)

Meter Parts Listing

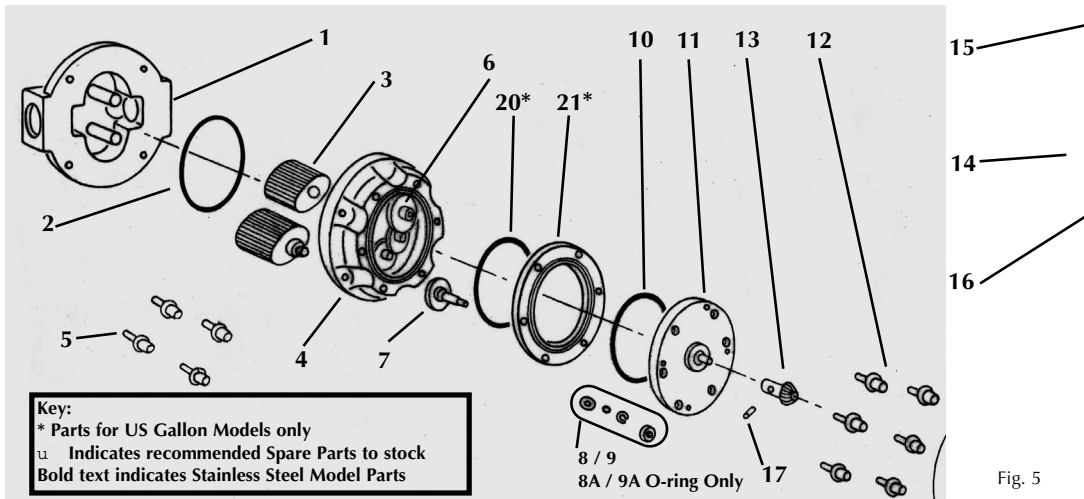

Fig. 5

Item No.	No. Off.	Rec. Parts	Part or Set (Order from this column only)	Part Description
1	1		MS298B	Meter Body 1/2" BSP (Aluminium)
			MS298N	Meter Body 1/2" NPT (Aluminium)
1	1		MS337B	Meter Body 1/2" BSP (Stainless Steel)
1	1		MS337N	Meter Body 1/2" NPT (Stainless Steel)
2	1	u	BS145S	"O" Ring (NBR)
2	1	u	BS145ES	"O" Ring (EPDM)
2	1	u	BS145TES	"O" Ring (Teflon)
2	1	u	BS145VS	"O" Ring (Viton)
3	2	u	MS342MS	Rotors PPS (Polyphenylene Sulfide Resins)
3	2	u	MS342MTS	High Temperature Rotors (PPS)
3	2	u	MS342MHS	High Viscosity Rotors (PPS)
3	2	u	MS342MHTS	High Viscosity/High Temperature Rotors (PPS)
4	1		MS544S	Meter Cap Liters (Aluminium)
4	1		MS547S	Meter Cap US Gallons (Aluminium)
4	1		MS545S	Meter Cap Liters (Stainless Steel)
4	1		MS546S	Meter Cap US Gallons (Stainless Steel)
5	4	u	MS346S	Meter Cap Screws (Standard)
5	4	u	MS350S	Meter Cap Screws (Stainless Steel)
6	1	u	MS539S	Complete Gear Set - Liters
6	1	u	MS541S	Complete Gear Set - US Gallons
7	1	u	MS77S	Output Gear & Shaft Assembly
8	1	u	MS78S	Coverplate Seal/Bush Set Standard
8A	1	u	OR42CS	Solvent o-ring (Perfluoro Elastomer)
9	1	u	MS78C	Coverplate Seal/Bush Set Solvent
9A	1	u	N7-007S	Standard o-ring (NBR)
9A	1	u	E7-007S	O-ring (EPDM)
9A	1	u	V7-007S	O-ring (Viton)
10	1	u	BS145S	O-ring (NBR)
10	1	u	BS145ES	O-ring (EPDM)
10	1	u	BS145TES	O-ring (Teflon)
10	1	u	BS145VS	O-ring (Viton)
11	1		MS99S	Coverplate (Aluminium) includes Bush
11	1		MS99-1S	Coverplate (Stainless Steel) includes Bush
12	6		MS312S	Coverplate Screws
12	6		MS313S	Coverplate Screws (Stainless Steel)
13	1		MS246S	Drive Dog
14	1		MS408	Encoder Adaptor
15	1		MS407S	Encoder
16	4		MS411S	Adaptor Screw Set
17	1		MS416	Grub Screw

Meter Parts Listing

Item No.	No. Off.	Rec. Parts	Part or Set (Order from this column only)	Part Description
20	1	u	BS145S	O-ring (NBR)
20	1	u	BS145ES	O-ring (EPDM)
20	1	u	BS145TES	O-ring (Teflon)
20	1	u	BS145VS	O-ring (Viton)
21	1		MS423S	Spacer Ring (Aluminium) US Galllon Models Only
21	1		MS423-1S	Spacer Ring (Stainless Steel) US Galllon Models Only

Encoder details



PLEASE READ THIS INFORMATION CAREFULLY BEFORE USE!

The encoder (Item 15, refer Figure 5) is an Optical Incremental shaft Encoder. It has a 1000 pulses per revolution resolution output. The output is an open collector with 3 phases (A, B and Z) that can function on a 5 to 12 Volts DC power supply.

Optical encoders are delicate instruments and should be treated with care. Shock loads and incorrect electrical connection will lead to Encoder damage.

To avoid electrical interference use quality shielded cable to connect the encoder to the recording instrument,

ensure the cable shield is grounded, as shown in wiring diagram below. The maximum allowable transfer distance for open collector encoders is 50 metres.

To avoid damage to the encoder please observe the manufactures electrical specifications, wiring table & wiring diagram shown below.

Electrical Specifications

Resolution	1000 pulses per rev.
Power Supply	DC5V -5% ~ DC12V +5%
Current Consumption	50mA Maximum
Output Form (Open Collector)	
Maximum Allowable Output Voltage	40V
Maximum Sink Current	30 mA
Maximum Response Frequency	200 kHz
Operating Temperature range	-10°C ~ +70°C
Encoder Protection	IP50
Maximum signal transfer distance	50 metres

Wiring Table

Lead Colour	Function
Red	DC + 5 ~ 12V
Black	GND
Yellow	Z channel output
White	GND
Blue	A channel output
Green	B channel output
Brown	-
Orange	-

Wiring Diagram

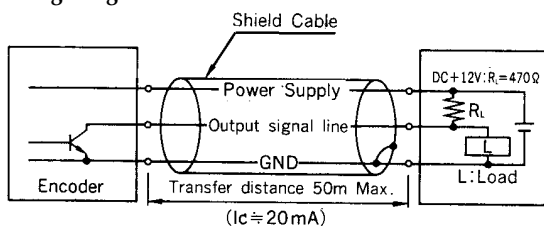

Wiring Diagram

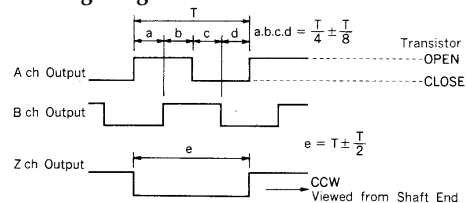

Note: The above voltage waveform can be obtained by loading RL as shown in the figure on the left.

Meter Specifications

Flow Ranges

(Litres per minute/US Gallons per minute)

Above 5 Centipoise	1 to 30/ 0.26 to 8
Below 5 Centipoise	3 to 25/ 0.8 to 6.6
Accuracy of Reading	+/- 1%
Maximum Viscosity	1000 Centipoise
Maximum Operating Pressure	3450 kPa / 500 PSI / 34.5 BAR
Maximum Operating Temperature	80°C / 176°F

Warranty

Macnaught Industries ('Macnaught') warrants that the Products will be free from any defects caused by faulty material or workmanship for a period of twelve (12) months from the date of sale of the Products to the enduser (the 'Warranty Period') PROVIDED THAT, during the Warranty Period:

1. Macnaught receives notice setting out full details of any defect in any product and details of the time and place of purchase of the Product: and

2. the enduser, at its own cost returns the Product to the nearest authorised Macnaught Service Centre.





Macnaught shall, as its option repair or replace any Product found defective by its inspection or refund the price paid by the enduser for that Product.

Macnaught's liability and the enduser's rights under this warranty shall be limited to such repair, replacement or refund and, in particular, shall not extend to any direct, special, indirect

or consequential damage or losses of any nature.

Note:

This warranty does not form part of, nor does it constitute, a contract between Macnaught and the enduser. It is additional to any warranty given by the seller of the Products and does not exclude, limit, restrict or modify the rights and remedies conferred upon the enduser, or the liabilities imposed on the seller, by any statute or other laws in respect of the sale of the Product.



www.bellflowsystems.co.uk

ISO 9001 Lic 8602
Standards Australia