



MACNAUGHT®

The experts in fluid technology

Positive displacement flowmeters

M2 series instruction manual

To the owner

Please take a few minutes to read through this manual before installing and operating your meter. Always retain this manual for future reference. If you have any problems with the meter, refer to the maintenance and trouble shooting sections of this manual.

This manual contains connection and operating instructions for the meters. If you need further assistance, contact your local representative or distributor for advice.

This Flowmeter has incorporated the

oval rotor principal into its design. This has proven to be a reliable and highly accurate method of measuring flow. Exceptional repeatability and high accuracy over a wide range of fluid viscosities and flow rates are features of the oval rotor design. With low pressure drop and high pressure rating means oval rotor flow meters are suitable for both gravity and pump (in-line) applications.

Flowmeters are available in either PPS (Polyphenylene Sulfide Resins),



Aluminium or 316 Stainless Steel. Standard rotors are made from 316 Stainless Steel with optional PPS rotors with Hastalloy C Shafts available.

Operation



PLEASE READ THIS INFORMATION CAREFULLY BEFORE USE!

Before use, confirm the fluid to be used is compatible with the meter. Refer to Industry fluid compatibility charts or consult your local representative for advice.

To prevent damage from dirt or foreign

matter it is recommended that a Y or basket type 200 mesh strainer be installed as close as possible to the inlet side of the meter. Contact your local representative for advice.

Note:

To prevent damage to the meter slowly fill the system with fluid (this will prevent damage caused by air purge).

Failure to do this could damage the meter.

To reduce pressure build up turn off the pump at the end of each day.

Installation

1. Use thread sealant on all pipe threads.
2. Ensure the meter is installed so that rotor shafts are always in a horizontal plane. Flow is bi-directional.

3. Macnought recommends use of flexible connections.

4. Extreme care must be taken when installing the meter. Pipe strain or overtightening meter connections can cause meter damage.

Pulsar details

Hall Effect Sensor Specifications;

- 1 4.5V to 24V (4.6 ~ 9mA) operation needs only an unregulated supply.
- 1 Open collector 25mA output NPN (Current Sink) compatible with digital logic.
- 1 Reverse battery protection.
- 1 Temperature -40°C / -40°F ~ 150°C / 300°F.

Reed Relay Specifications;

- 1 Two wire SPST N/O.
- 1 Switching voltage 150VDC maximum current 0.25 AMPS.
- 1 Rating 3 watts.
- 1 Temperature -40°C / -40°F ~ 150°C / 300°F.
- 1 Duty Cycle 20% on 80% off.

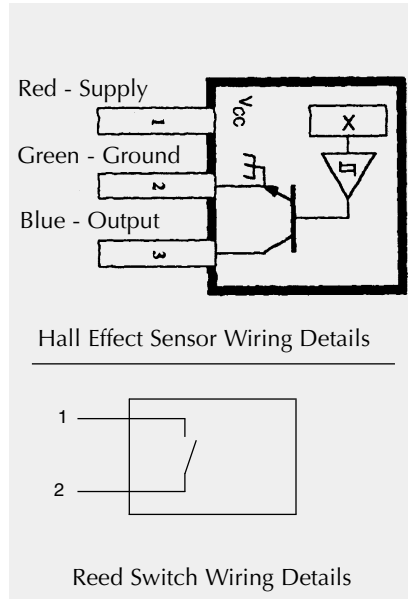

Note: The groove on the cover must line up with the groove on the meter body (refer to diagram).

Maintenance

Disassembly:

1. Ensure the fluid supply to the meter has been disconnected, and the line pressure has been released before disassembly.
2. Remove four (4) screws (Item 3) and remove the meter body cover (Item 2).
3. Remove o-ring (Item 5) and inspect (replace o-ring if damaged).
4. Remove rotors (Item 4), clean and inspect (replace rotors if damaged).

Reassembly:

1. Place rotors (Item 4) into the meter body. The rotors should be at 90° to each other.
- Note: The rotor with magnets must be placed in the body on the same side as the groove on the body (refer to diagram).
2. Lightly rotate the rotors (Item 4) by hand (they must rotate freely).
 3. Install o-ring (Item 5).
 4. Replace the meter cap (Item 2).

5. Replace four screws (Item 3).



CAUTION:
Care must be taken not to overtighten the screws (Item 3) or damage may occur.

Display parts listing

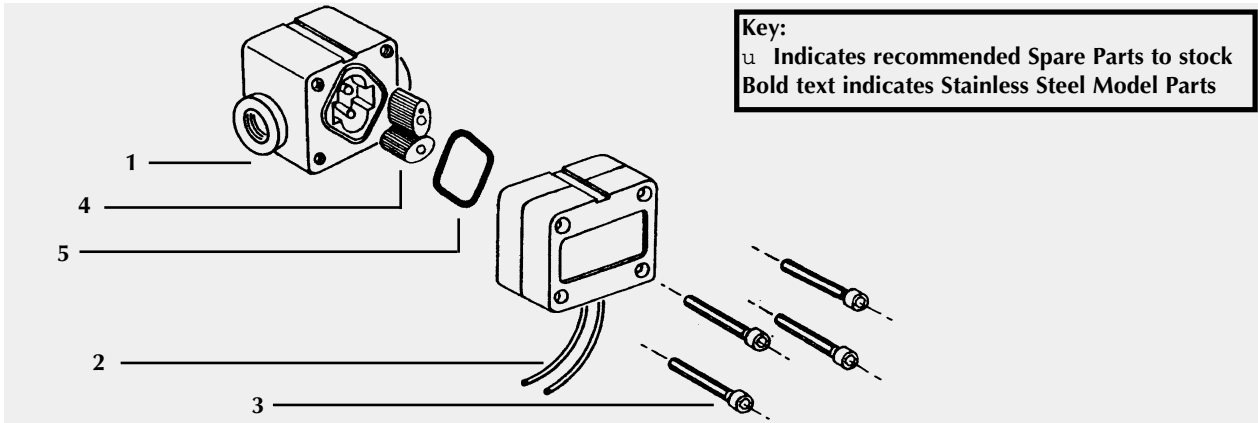

Key:
 u Indicates recommended Spare Parts to stock
Bold text indicates Stainless Steel Model Parts

Item No.	No. Off.	Rec. Parts	Part or Set (Order from this column only)	Part Description
1	1		MS2R-1S	Meter Body Assy. (BSP)
1	1		MS2R-1C	Meter Body Assy. (BSP) Hastalloy C Shafts
1	1		MS2S-1S	Meter Body Assy. (BSP) Stainless Steel
1	1		MS2R-2S	Meter Body Assy. (NPT)
1	1		MS2R-2C	Meter Body Assy. (NPT) Hastalloy C Shafts
1	1		MS2S-2S	Meter Body Assy. (NPT) Stainless Steel
1	1		MS2AL-1S	Meter Body Assy. (BSP) Aluminium
1	1		MS2AL-2S	Meter Body Assy. (NPT) Aluminium
2	1	u	MS3R-S	Meter Cap Hall Effect Sensor
2	1	u	MS3S-S	Meter Cap Hall Effect Sensor Stainless Steel
2	1	u	MS3R-SR	Meter Cap Reed Switch (Ryton & Alumin. Models)
2	1	u	MS3S-SR	Meter Cap Reed Switch Stainless Steel
3	4	u	MS98s	Screws (Ryton & Alumin. Models)
3	4	u	MS113s	Screws Stainless Steel
4	2	u	MS7-1Es	Rotor SS Hall (Set)
4	2	u	MS7-1HEs	Rotor SS High Viscosity Hall (Set)
4	2	u	MS7-1Rs	Rotor SS Reed (Set)
4	2	u	MS7-1HRs	Rotor SS Reed High Viscosity (Set)
4	2	u	MS7Rs	Rotor PPS Reed (Set)
4	2	u	MS7Es	Rotor PPS Hall (Set)
5	1	u	BS127Vs	O-ring (Viton)
5	1	u	BS127Ps	O-ring (Perfluoro Elastomer)
5	1	u	BS127Es	O-ring (EPDM)

Meter specifications

Meter Type	SS & Ryton Models	Aluminium Models
Flow Ranges (Litres/hr or US Gall./hr)	15 to 500 / 4 to 132	15 to 500 / 4 to 132
Above 5 centipoise	25 to 500 / 6.6 to 132	25 to 500 / 6.6 to 132
Below 5 centipoise	+/- 1%	+/- 1%
Accuracy of Reading	1000 Centipoise	1000 Centipoise
Maximum Viscosity	500kPa/75PSI/5Bar	500kPa/75PSI/5Bar
Max. Operating Pressure	Ryton Models SS Models	
Maximum Operating Temperature	80°C / 176°F	80°C / 176°F
Pulse Type	Hall Effect Sensor/Reed Switch	Hall Effect Sensor/Reed Switch
Pulses per Litre/US Gallons	400/1514	400/1514
Meter Dimensions (Width x Height)	50x50mm / 1.97" x 1.97"	50x50mm / 1.97" x 1.97"
Meter Dimensions Port Face to Face	65mm / 2.58"	60mm / 2.36"
Weight	600g / 21.2oz	320g / 12oz
Wetted Components	SS Models Ryton Models	6061 Alum., 316 SS, Ryton Zirconia Bush

Trouble shooting

TROUBLE SHOOTING GUIDE		
TROUBLE	CAUSE	REMEDY
Fluid will not flow through the meter	A) Foreign matter blocking rotors B) Line strainer blocked C) Damaged rotors D) Meter connections over tightened	A) Dismantle meter, clean rotors (Strainer must be fitted in line.) B) Clean strainer C) Replace rotors (Strainer must be fitted in line) D) Re-adjust connections
Reduced flow through the meter	A) Line strainer partially blocked B) Fluid is too viscous	A) Clean strainer B) Maximum viscosity 1000 centipoise
Meter reading inaccurate	A) Fluid flowrate is too low or too high B) Air in fluid C) Excess wear caused by incorrect installation	A) See specifications for min. and max. flowrates B) Bleed air from system C) Check meter body and rotors
Meter not giving a pulse signal	A) Faulty hall effect sensor or reed switch B) Faulty magnet C) Rotors installed in wrong position	A) Replace meter cap B) Replace rotors C) Refer to correct rotor positioning - assembly instructions.

Warranty

Macnaught Industries ('Macnaught') warrants that the Products will be free from any defects caused by faulty material or workmanship for a period of twelve (12) months from the date of sale of the Products to the enduser (the 'Warranty Period') PROVIDED THAT, during the Warranty Period:

1. Macnaught receives notice setting out full details of any defect in any product and details of the time and place of purchase of the Product: and

2. the enduser, at its own cost returns the Product to the nearest authorised Macnaught Service Centre.

Macnaught shall, as its option repair or replace and Product found defective by its inspection or refund the price paid by the enduser for that Product.

Macnaught's liability and the enduser's rights under this warranty shall be limited to such repair, replacement or refund and, in particular, shall not

extend to any direct, special, indirect or consequential damage or losses of any nature.

Note:

This warranty does not form part of, nor does it constitute, a contract between Macnaught and the enduser. It is additional to any warranty given by the seller of the Products and does not exclude, limit, restrict or modify the rights and remedies conferred upon the enduser, or the liabilities imposed on the seller, by any statute or other laws in respect of the sale of the Product.



MACNAUGHT®



Quality System
Quality Endorsed Company



www.bellflowsystems.co.uk

ISO 9001 Lic 8602
Standards Australia