



MS16HP
0303
0003

MACNAUGHT®

The experts in fluid technology

Positive displacement flowmeters

MI HP series instruction manual

To the owner

Please take a few minutes to read through this manual before installing and operating your meter. Always retain this manual for future reference. If you have any problems with the meter, refer to the maintenance and trouble shooting sections of this manual.

This manual contains connection and operating instructions for the meters. If you need further assistance, contact your local representative or distributor for advice.

This Flowmeter has incorporated the oval rotor principal into its design. This

has proven to be a reliable and highly accurate method of measuring flow. Exceptional repeatability and high accuracy over a wide range of fluid viscosities and flow rates are features of the oval rotor design. With low pressure drop and high pressure rating means oval rotor flow meters are suitable for both gravity and pump (in-line) applications.

Flowmeters and rotors are manufactured in 316 Stainless Steel only.



Operation



PLEASE READ THIS INFORMATION CAREFULLY BEFORE USE!

Before use, confirm the fluid to be used is compatible with the meter. Refer to Industry fluid compatibility charts or consult your local representative for advice.

To prevent damage from dirt or foreign matter it is recommended that a Y or basket type 200 mesh strainer be installed as close as possible to the inlet side of the meter. Contact your local representative for advice.

Note:

To prevent damage to the meter slowly

fill the system with fluid (this will prevent damage caused by air purge). Failure to do this could damage the meter.

To reduce pressure build up turn off the pump at the end of each day.

Installation

1. Use thread sealant on all pipe threads.
2. Ensure the meter is installed so that rotor shafts are always in a horizontal plane. Flow is bi-directional.
3. The use of flexible connections is recommended.
4. Extreme care must be taken when installing the meter. Pipe strain or overtightening meter connections can cause meter damage.

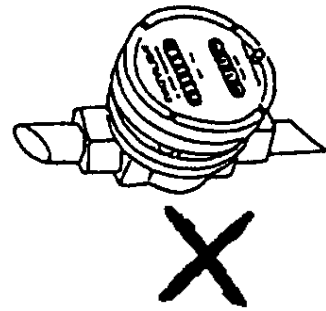

DO NOT INSTALL METER THIS WAY

Pulser details

Hall Effect Sensor Specifications;

- 1 4.5V to 24V (4.6 ~ 9mA) operation needs only an unregulated supply.
- 1 Open collector 25mA output NPN (Current Sink) compatible with digital logic.
- 1 Reverse battery protection.
- 1 Temperature -40°C / -40°F ~ 150°C / 300°F.

Reed Relay Specifications;

- 1 Two wire SPST N/O.
- 1 Switching voltage 150VDC maximum current 0.25 AMPS.
- 1 Rating 3 watts.
- 1 Temperature -40°C / -40°F ~ 150°C / 300°F.
- 1 Duty cycle 20% on 80% off.

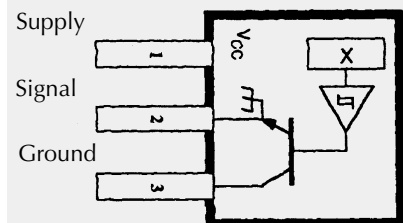

Hall Effect Sensor Wiring Details (HP Models only)

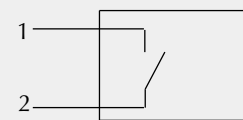

Reed Switch Wiring Details (HP Models only)

Maintenance

Disassembly:

1. Ensure the fluid supply to the meter has been disconnected, and the line pressure has been released before disassembly.
2. Remove four (4) screws (Item 4) and remove the pulser cap (Item 3).
3. Remove the gasket (Item 9).
4. Remove eight (8) screws (Item 2) and remove the meter cap (Item 6).
5. Remove o-ring (Item 8) and inspect (replace o-ring if damaged).
6. Remove rotors (Item 7), clean and inspect (replace rotors if damaged).
7. To remove the PCB (Item 5) remove the 2 screws (Item 10). **Note: Reed switch PCB's cannot be removed.**

Reassembly:

1. Place rotors (Item 7) into the meter body. The rotors should be at 90° to each other.

2. Lightly rotate the rotors (Item 7) by hand (they must rotate freely).

3. Install o-ring (Item 8).
4. Replace the meter cap (Item 6) and tighten the 8 screws (Item 2) uniformly to 35Nm (25 Ft.lbs).
5. Replace the pulser cap (Item 3) and tighten the 4 screws (Item 4).

Display parts listing

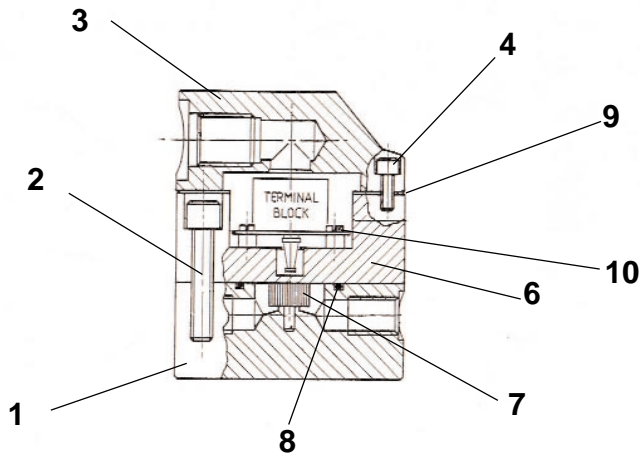

Key:
u Indicates recommended Spare Parts to stock
Bold text indicates Stainless Steel Parts

Item No.	No. Off.	Rec. Parts	Part or Set (Order from this column only)	Part Description
1	1		MS1BS	Meter Body Assy. (BSP)
1	1		MS1NS	Meter Body Assy. (NPT)
2	8	u	MS367S	Bolt set - Socket Head
3	1		MS170H	Pulser Cap (BSP)
3	1		MS170HN	Pulser Cap (NPT)
4	4	u	MS115S	Bolt set - Socket Head
6	1		MS3HES	Meter Cap & Hall Effect assembly*
6	1		MS3HPS	Meter Cap & Reed switch assembly*
7	2	u	MS6-1S	Rotor Set Stainless Steel
8	1	u	BS127VS	O-ring (Viton)
8	1	u	BS127ES	O-ring (EPM)
8	1	u	BS127Ps	O-ring (Perfluoroelastomer)
9	1	u	MS300Hs	Gasket
10	1		MS284s	Screw Sets

*Reed switch & Hall effect are unavailable without meter cap.

Meter specifications

Meter Type	Pulse
Flow Ranges (Litres per hour/US Gallons per hour)	
Above 5 centipoise	2 to 100 / 0.53 to 26.4
Below 5 centipoise	5 to 100 / 1.32 to 26.4
Accuracy of Reading	+/- 1%
Maximum Viscosity	1000 Centipoise
Maximum Operating Pressure	55160kpa/8000psi/551Bar
Maximum Operating Temperature	120°C / 248°F
Pulse Type	Hall Effect Sensor / Reed Switch
Pulses per Litre/US Gallons	1000/3785
Meter Dimensions	86mm Dia./ 3.4" Dia(Meter Body) 83mm / 3.25" (Port Face to Face)
Weight	3.3Kg / 116oz

Trouble shooting

TROUBLE SHOOTING GUIDE		
TROUBLE	CAUSE	REMEDY
Fluid will not flow through the meter	A) Foreign matter blocking rotors B) Line strainer blocked C) Damaged rotors D) Meter connections over tightened	A) Dismantle meter, clean rotors (Strainer must be fitted in line.) B) Clean strainer C) Replace rotors (Strainer must be fitted in line) D) Re-adjust connections
Reduced flow through the meter	A) Line strainer partially blocked B) Fluid is too viscous	A) Clean strainer B) Maximum viscosity 1000 centipoise
Meter reading inaccurate	A) Fluid flowrate is too low or too high B) Air in fluid C) Excess wear caused by incorrect installation	A) See specifications for min. and max. flowrates B) Bleed air from system C) Check meter for damage, Install correctly
Meter not giving a pulse signal	A) Faulty hall effect sensor or reed switch B) Faulty magnet	A) Replace meter cap for reed switch models, replace PCB for Hall effect models B) Replace rotors

Warranty

Macnaught Industries ('Macnaught') warrants that the Products will be free from any defects caused by faulty material or workmanship for a period of twelve (12) months from the date of sale of the Products to the enduser (the 'Warranty Period') PROVIDED THAT, during the Warranty Period:

1. Macnaught receives notice setting out full details of any defect in any product and details of the time and place of purchase of the Product: and

2. the enduser, at its own cost returns the Product to the nearest authorised Macnaught Service Centre.

Macnaught shall, as its option repair or replace any Product found defective by its inspection or refund the price paid by the enduser for that Product.

Macnaught's liability and the enduser's rights under this warranty shall be limited to such repair, replacement or refund and, in particular, shall not extend to any direct, special, indirect

or consequential damage or losses of any nature.

Note:

This warranty does not form part of, nor does it constitute, a contract between Macnaught and the enduser. It is additional to any warranty given by the seller of the Products and does not exclude, limit, restrict or modify the rights and remedies conferred upon the enduser, or the liabilities imposed on the seller, by any statute or other laws in respect of the sale of the Product.



MACNAUGHT®



BELL
Flow Systems

www.bellflowsystems.co.uk



Quality System
Quality Endorsed Company

ISO 9001 Lic 8602
Standards Australia