

MS51
0702
0002



# MACNAUGHT®

## The experts in fluid technology

---

---

### Positive Displacement Flowmeters

— MIO series instruction manual —



MIO Pulse • MIO Standard LCD • MIO Deluxe LCD • From serial No. CXXXX

---

---

---

# To the owner

---

Please take a few minutes to read through this manual before installing and operating your meter. Always retain this manual for future reference. If you have any problems with the meter, refer to the maintenance and trouble shooting sections of this manual.

This manual contains connection and operating instructions for meters with Pulse outputs and Liquid Crystal Displays. Each model with a Liquid Crystal Display has an additional LCD instruction manual supplied. If you

need further assistance, contact your local representative or distributor for advice.

This Flow Meter has incorporated the oval rotor principal into its design. This has proven to be a reliable and highly accurate method of measuring flow. Exceptional repeatability and high accuracy over a wide range of fluid viscosities and flow rates are features of the oval rotor design. With low pressure drop and high pressure rating oval rotor flow meters are suitable for both gravity and pump (in line)

applications.

Flow meters are available in either Bronze, Aluminium or 316 Stainless Steel. Standard rotors are made from PPS with optional 316 Stainless Steel rotors available for both Stainless Steel and Aluminium models.

Meters are available with either;

- \* Pulse output
- \* Standard LC Display and Pulse
- \* Deluxe LC Display and Pulse

---

## Important Information

---



### PLEASE READ THIS INFORMATION CAREFULLY BEFORE USE!

Before use, confirm the fluid to be used is compatible with the meter. Refer to industry fluid compatibility charts or consult your local representative for advice.

To prevent damage from dirt or foreign matter it is recommended that a Y or Basket type 60 mesh strainer be installed as close as possible to the inlet side of the meter. Contact your

local representative for advice.

**Note:** When a strainer is installed it should be regularly inspected and cleaned. Failure to keep the strainer clean will dramatically effect flow meter performance.

**Note:** To prevent damage caused by air purge slowly fill the meter with fluid.

To reduce pressure build up turn off the pump at the end of each day.

Maintenance can be carried out to the

liquid crystal displays and pulse units without removing or isolating the meter from the line. When maintenance to any other part of the meter is required, the meter must be isolated and the line pressure reduced.

The reed switch pulse unit can cause inaccurate rate counts when used with high speed counters. It is advised that a debounce circuit be used. Contact your meter distributor for further information.

---

## Operating Principle

---

When fluid passes through the meter the rotors turn, as shown below. The magnets which are located in the rotors will pass across the pulser circuit board

(containing either Reed switches or Hall Effect sensors). A signal is generated which is then sent by the Pulse Circuit Board (PCB) to the

relevant LC display or receiving instrument.

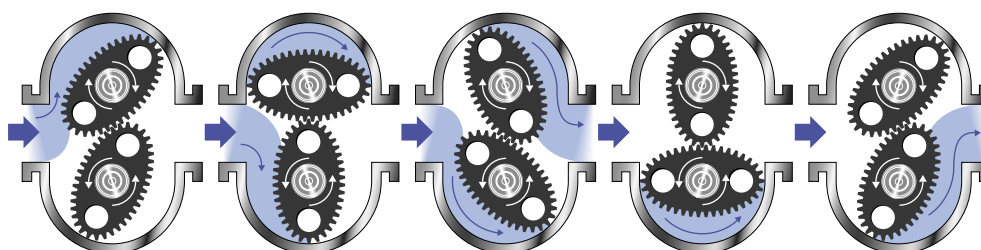

# Installation

- 1] it is recommended that when setting up pipework for meter installations a bypass line be included in the design. This provides the facility for a meter to be removed for maintenance without interrupting production. (See Fig.1)
- 2] Use thread sealant on all pipe threads.
- 3] For pump applications ensure pipe work has the appropriate working pressure rating to match the pressure output of the pump. See Meter Specifications section for further details.
- 4] Install a wire mesh strainer (Y or basket type 60 mesh as close as possible to the inlet side of the meter.
- 5] Ensure that the meter is installed so that the flow of the liquid is in the direction of the arrows embossed on the meter body.
- 6] The meter can be installed in any orientation as long as the meter shafts are in a horizontal plane. (Refer to Fig.2 for correct installation) The register assembly may be orientated to suit the individual installation.

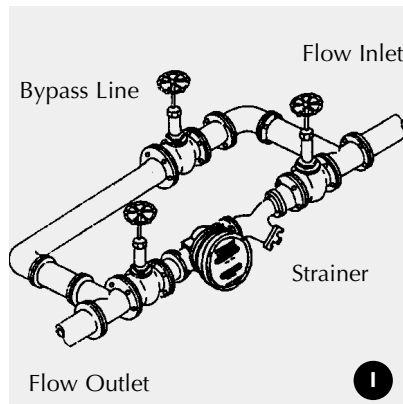

Note: Incorrect installation can cause premature wear of meter components.

- 7] Do not over tighten meter connections.
- 8] **It is important that after initial installation you fill the line slowly, high speed air purge could cause damage to the rotors.**
- 9] Test the system for leaks.
- 10] Check the strainer for swarf or foreign material, after the first 200 litres check periodically, particularly if the flow rate decreases.

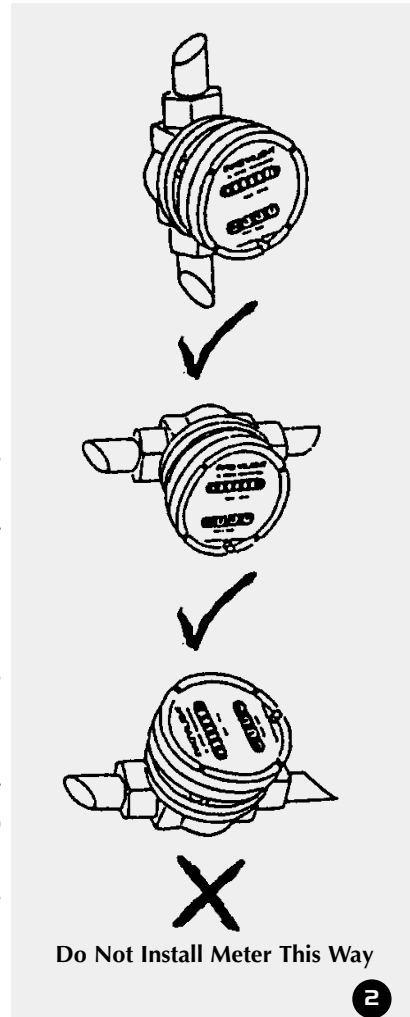

# Electrical Connections

## Reed Switch Connections

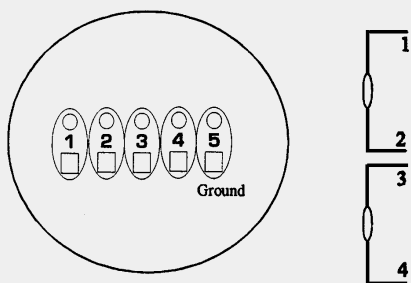

Contact rating 15VA  
Maximum Voltage 150VDC  
**Note:** Double rate pulse output not available

3

## Hall Effect or Reed/Hall Sensor Connections

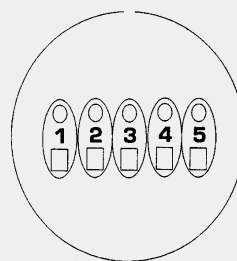

### Reed/Hall combination

- 1 - Reed Switch
- 2 - Reed Switch
- 3 - HE Common -
- 4 - HE Signal
- 5 - HE Supply +

### Hall/Hall Combination

- 1 - HE1 Supply +
- 2 - HE1 Signal
- 3 - HE Common -
- 4 - HE2 Signal
- 5 - HE2 Supply +

Hall Effect Voltage 4.5 to 24 VDC  
Current Draw Minimum 4.6mA  
Output NPN Open Collector 25mA

**Note:** Std. & Deluxe LCD must be driven by a Reed switch

4

# Service Instructions

## Disassembly

Ensure that the fluid supply to the meter is disconnected, and the line pressure is released before disassembly, with the exception for repair or maintenance to the LC Display or PCB where there is no necessity to isolate the meter from flow. Refer to the exploded parts diagram on subsequent pages for item numbers.

**1a) Pulse Caps models:** Undo the conduit connector, remove pulse cap (item 9) and remove the wires from the pulse terminal board (item 5).

**1b) Standard LC Display:** Mark the display orientation with a marking pen, unscrew the four large screws (Item 26) on top of the LC Display. Carefully separate the LC Display from the plastic housing and disconnect the wires from the pulse terminal block. (Refer to additional Standard LC Display instruction manual).

**1c) Deluxe LC Display:** Mark the display orientation with a marking pen, remove the four retaining screws on the display face (Item 16). Lift off the display unit and remove the 9 pin connector at the back of the display unit. (Refer to additional Deluxe LC Display instruction manual).

**2]** Remove the mounting adaptor plate and gasket (Item 14).

**3]** Loosen the cap head screws (Item 7) that hold down the meter cap (Item 4), remove the screws, washers and lift off the cap.

**4]** Remove the o'ring (Item 2) from the o'ring groove in the meter cap (Item 4).

**5]** Remove rotors (Item 3). Note the position of the timing marks.

## Reassembly

**1]** Before reassembling check the condition of the rotors (replace if necessary).

**2]** Check that the plug side of the rotors is facing you when inserting the rotors, the plug side of the rotor is the magnet side. There is no difference between rotor one or rotor two.

**3]** Replace the rotors (Item 3) onto the shafts at 90° to each other (refer Fig. 5). Check the operation of the rotors by turning either by hand. If the rotors are not in mesh correctly or do not move freely, remove one of the rotors and replace correctly at 90° to the other rotor. Re-check the operation of the rotors.

**4]** Replace the o'ring (Item 2) into groove in the meter cap, if the o'ring has grown or is damaged in any way replace it with a new part.

**5]** Replace the meter cap making sure that the locating pin in the body lines up with the hole in the meter cap. Insert the cap head screws (Item 7) and tighten in a diagonal sequence 1, 3, 2, 4, etc.

**6]** The replacement of cables and connectors are a reversal of the disassembly procedure, replace conduit fitting if required. When replacing the Standard LC Display

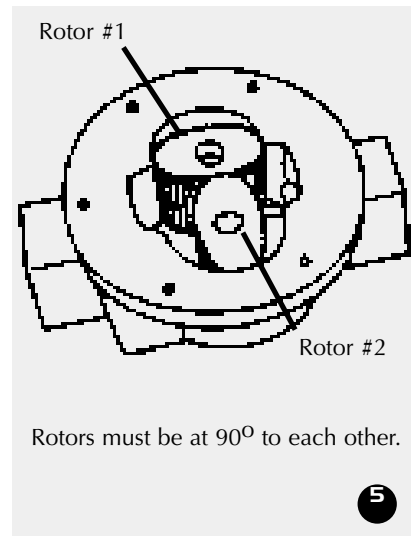

or the Deluxe LC Display, confirm the orientation marks made on disassembly are aligned then screw the register into place.

**7]** Test the meter by turning the rotors with a finger or by applying very low air pressure (no more than a good breath) to one end of the meter, before returning the meter to the line.

## Pulse Circuit Board (PCB) Notes:

The pulse PCB (Item 5) is fitted with (A) two reed switches; (B) hall effect sensors; or (C) one reed switch and one hall effect sensor. The PCB board is fastened to the meter cap (Item 4) by two screws and stand off's. All care and caution should be taken when removing or handling the PCB as both the reed switch and hall effect sensor are fragile.

Reed switch or hall effect sensors are not available as individual replacement parts and are only available with the complete PCB (Item 5).

# Meter Parts Listing

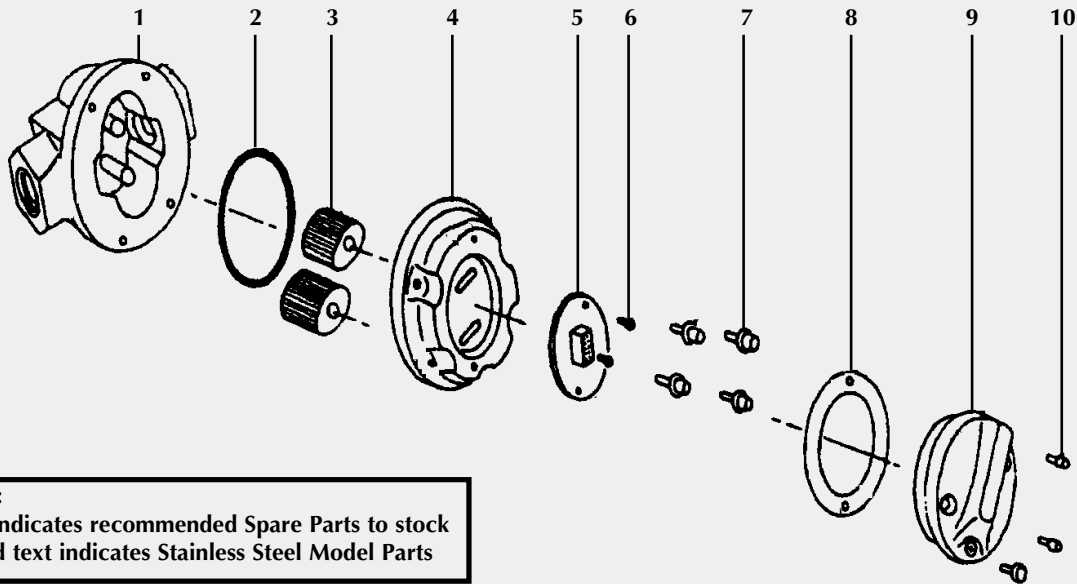

**Key:**  
 u Indicates recommended Spare Parts to stock  
 Bold text indicates Stainless Steel Model Parts

Item No.	No. Off.	Rec. Parts	Part or Set (Order from this column only)	Part Description
1	1		MS187B	Meter Body 1" BSP (Aluminium)
1	1		MS187N	Meter Body 1" NPT (Aluminium)
<b>1</b>	<b>1</b>		<b>MS185B</b>	<b>Meter Body 1" BSP (Stainless Steel)</b>
<b>1</b>	<b>1</b>		<b>MS185N</b>	<b>Meter Body 1" NPT (Stainless Steel)</b>
1	1		MS187F	Meter Body 1" ANSI 150lb Flange (Aluminium)
1	1		MS187D	Meter Body 1" DIN16 Flange (Aluminium)
1	1		MS187J	Meter Body 1" JIS 10K Flange (Aluminium)
<b>1</b>	<b>1</b>		<b>MS185F</b>	<b>Meter Body 1" ANSI 150lb Flange (S/Steel)</b>
<b>1</b>	<b>1</b>		<b>MS185D</b>	<b>Meter Body 1" DIN16 Flange (S/Steel)</b>
<b>1</b>	<b>1</b>		<b>MS185T</b>	<b>Meter Body 1" Tri-Clover Flange (S/Steel)</b>
<b>1</b>	<b>1</b>		<b>MS185J</b>	<b>Meter Body 1" JIS 10K Flange (S/Steel)</b>
2	1	u	BS235	"O" Ring (NBR)
2	1	u	BS235E	"O" Ring (EPDM)
2	1	u	BS235TE	"O" Ring (Teflon)
2	1	u	BS235V	"O" Ring (Viton)
3	2	u	MS50S	Rotors PPS (Polyphenylene Sulfide Resins)
<b>3</b>	<b>2</b>	<b>u</b>	<b>MS50-1S</b>	<b>Rotors (Stainless Steel)</b>
3	2	u	MS50TS	High Temperature Rotors (PPS)
3	2	u	MS50HS	High Viscosity Rotors (PPS)
3	2	u	MS50HTS	HighViscosity/High Temperature Rotors (PPS)
<b>3</b>	<b>2</b>	<b>u</b>	<b>MS50-1HS</b>	<b>High Viscosity Rotors (Stainless Steel)</b>
4	1		MS150	Meter Cap (Aluminium)
<b>4</b>	<b>1</b>		<b>MS250</b>	<b>Meter Cap (Stainless Steel)</b>
5	1	u	MS28-R	PCB (Standard Reed Switch)
5	1	u	MS28-HE	PCB (Hall Effect Sensor)
5	1		MS28-R/HE	PCB ( 1 Reed Switch & 1 Hall Effect Sensor)
6	4		MS111S	PCB Board Screws
7	6	u	MS114S	Meter Cap Screws (Standard)
<b>7</b>	<b>6</b>	<b>u</b>	<b>MS200S</b>	<b>Meter Cap Screws (Stainless Steel)</b>
8	1	u	MS300	Pulser Cap Gasket
9	1		MS160	Pulser Cap (Aluminium) 20mm Conduit Thread
9	1		MS160N	Pulser Cap (Aluminum) 1/2" NPT Thread
<b>9</b>	<b>1</b>		<b>MS170</b>	<b>Pulser Cap (Stainless Steel) 20mm Conduit Thread</b>
<b>9</b>	<b>1</b>		<b>MS170N</b>	<b>Pulser Cap (Stainless Steel) 1/2" NPT Thread</b>
10	4		MS115S	Pulser Cap Screw (Stainless Steel)
11	1		MS37	Warning Label (Not Shown)
12	1		MS14	Explosion Proof Approval Label (Not Shown)
13	1		Customer to Specify	Legend Plate (Not Shown) inc. Hammer Screws

# Display Parts Listing

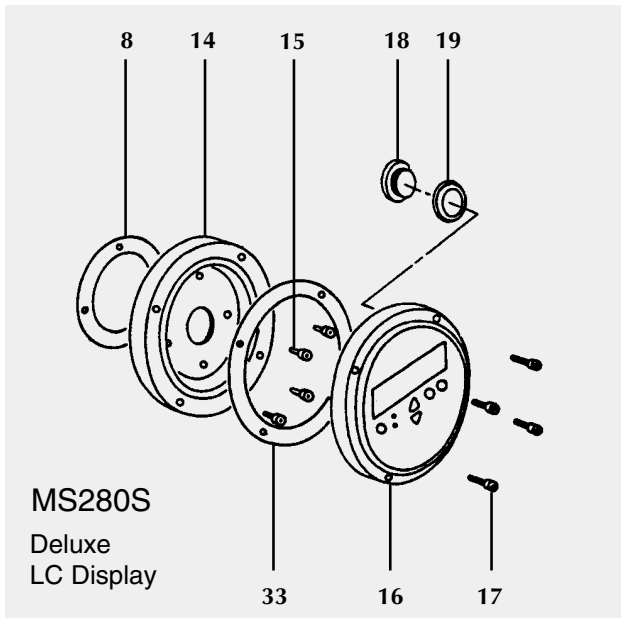

**MS280S**  
Deluxe  
LC Display

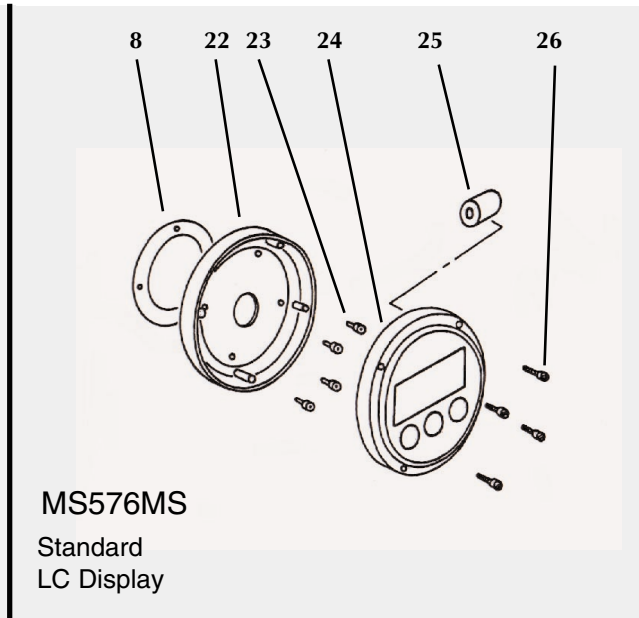

**MS576MS**  
Standard  
LC Display

Item No.	No. Off.	Rec. Parts	Part or Set (Order from this column only)	Part Description
			<b>MS280S</b>	<b>Deluxe LCD Display (Complete)</b>
14	1		MS279S	Mounting Adaptor Plate
15	4	u	MS117S	Adaptor Screws
16	1	u	MS69S	LC Display Unit
17	4	u	MS118S	LC Display Mounting Screws
18	1	u	MS127	Battery Retaining Screw
19	1	u	MS126	Battery (Standard) CR2040
20	1	u	MS68	Connector and Cable (Not Shown)
21	1	u	MS87	PTB Approval Label (Not Shown)
22	1	u	MS128S	Extended Life Battery 2/3 AA (Not Shown)
33	1	u	MS307S	NOTE: Not Suitable for Intrinsic Use Gasket
			<b>MS576MS</b>	<b>Standard LC Display (Complete)</b>
22	1		MS572S	Mounting Adaptor Plate
23	4	u	MS115S	Adaptor Screws
24	1	u	MS570S	LC Display Module
25	1	u	MS493S	3.6 Volt Battery (Lithium) Size C
26	4	u	MS129S	Register Screws

# Heating Jackets

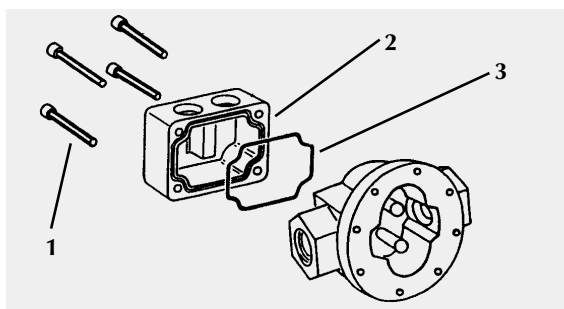

**Complete Assembly:** HJ100-1 - Aluminium BSP  
HJ100-2 - Aluminium NPT

**Spare Parts Listing:**

**HJ100-1:** MS320 SHCS Screws  
MS134B Jacket Body - Aluminium/BSP  
OR692 "O" Ring

**HJ100-2:** MS320 SHCS Screws  
MS134N Jacket Body - Aluminium/NPT  
OR692 "O" Ring

# Meter Specifications

Meter Type	Pulse	Pulse with Standard LC Display	Pulse with Deluxe LC Display
<b>Flow Ranges</b> (Litres per minute/US Gallons per minute) <b>Above 5 Centipoise</b> <b>Below 5 Centipoise</b>	6 to 120/ 1.6 to 32 10 to 100/ 2.6 to 26	6 to 120/ 1.6 to 32 10 to 100/ 2.6 to 26	6 to 120/ 1.6 to 32 10 to 100/ 2.6 to 26
<b>Accuracy of Reading</b>	+/- 0.5%	+/- 0.5%	+/- 0.5%
<b>Maximum Viscosity*</b>	1000 Centipoise	1000 Centipoise	1000 Centipoise
<b>Maximum Operating Pressure</b>	5500 kPa/ 800 PSI/ 55 BAR	5500 kPa/ 800 PSI/ 55 BAR	5500 kPa/ 800 PSI/ 55 BAR
<b>Maximum Operating Temperature</b>	80°C/ 176°F (Stainless Steel Models 120°C/ 248°F)	80°C/ 176°F (Stainless Steel Models 120°C/ 248°F)	80°C/ 176°F (Stainless Steel Models 120°C/ 248°F)
<b>Pulse Type</b>	Dual Reed Switches or Hall Effect Sensor or combination HE Sensor/Reed Switch	Dual Reed Switches or Hall Effect Sensor or combination HE Sensor/Reed Switch	Dual Reed Switches or Hall Effect Sensor or combination HE Sensor/Reed Switch
<b>Pulses Per Litre/US Gallon</b>	36/ 72 or 136.3/ 272.6	36/ 136.3	36/ 136.3

\* Unless High Viscosity or High Temperature Rotors are fitted

# Meter Trouble Shooting

TROUBLE	CAUSE	REMEDY
Fluid will not flow through meter	<b>a]</b> Foreign matter blocking rotors <b>b]</b> Line strainer blocked <b>c]</b> Damaged rotors <b>d]</b> Meter connections over tightened <b>e]</b> Fluid is too viscous	<b>a]</b> Dismantle meter, clean rotors (Strainer must be fitted in line) <b>b]</b> Clean strainer <b>c]</b> Replace rotors (Fit strainer) <b>d]</b> Re-adjust connections <b>e]</b> See specifications for maximum viscosity
Reduced flow through the meter	<b>a]</b> Strainer is partially blocked <b>b]</b> Fluid is too viscous	<b>a]</b> Clean strainer <b>b]</b> See specifications for maximum viscosity
Meter reading inaccurate	<b>a]</b> Fluid flow rate is too high or too low <b>b]</b> Fluid is too viscous <b>c]</b> Excess wear caused by incorrect installation	<b>a]</b> See specifications for minimum and maximum flow rates <b>b]</b> Bleed air from system <b>c]</b> Check meter body and rotors. Replace as required. Refer to installation instructions
Meter not giving a pulse signal	<b>a]</b> Faulty hall effect sensor <b>b]</b> Faulty reed switch <b>c]</b> Magnets failed	<b>a]</b> Replace PCB Board <b>b]</b> Replace PCB Board <b>c]</b> Replace magnets
LCD Register not working	<b>a]</b> Battery not connected properly <b>b]</b> Battery flat <b>c]</b> Faulty wiring connections <b>d]</b> Faulty LC display <b>e]</b> Faulty connection from LC display to Pulse PCB	<b>a]</b> Check battery connections <b>b]</b> Replace battery <b>c]</b> Check wiring for loose or faulty connections <b>d]</b> Replace LC display <b>e]</b> Check wiring connections

# Meter Dimensions

## M10 Pulse Meter Dimensions

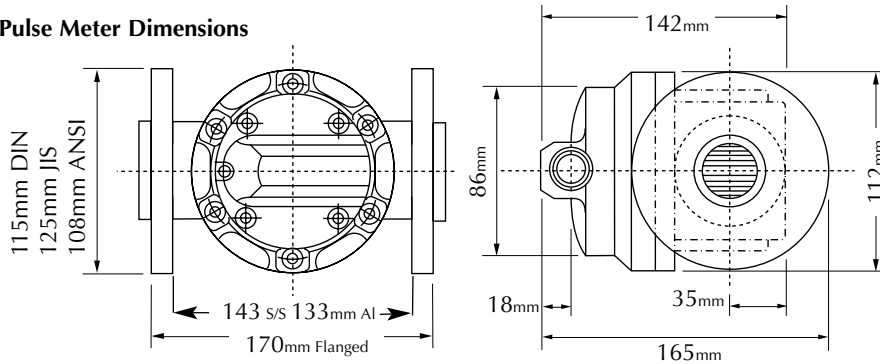

## M10 Pulse Meter with Standard or Deluxe LC Display

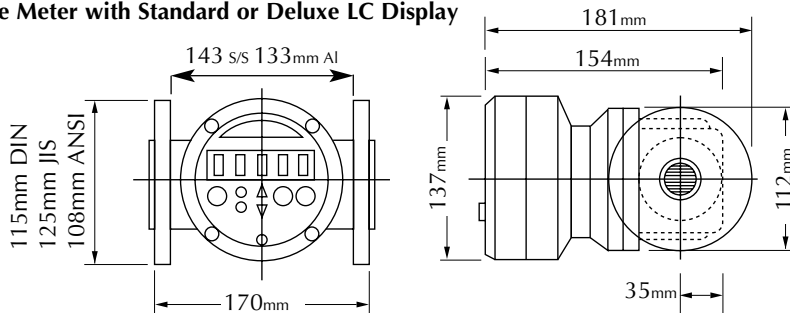

# Warranty

Macnaught Industries ('Macnaught') warrants that the Products will be free from any defects caused by faulty material or workmanship for a period of twelve (12) months from the date of sale of the Products to the enduser (the 'Warranty Period') PROVIDED THAT, during the Warranty Period:

1. Macnaught receives notice setting out full details of any defect in any product and details of the time and place of purchase of the Product: and

2. The enduser, at its own cost returns the Product to the nearest authorised Macnaught Service Centre.

Macnaught shall, as its option repair or replace and Product found defective by its inspection or refund the price paid by the enduser for that Product.

Macnaught's liability and the enduser's rights under this warranty shall be limited to such repair, replacement or refund and, in particular, shall not

extend to any direct, special, indirect or consequential damage or losses of any nature.

**Note:** This warranty does not form part of, nor does it constitute, a contract between Macnaught and the enduser. It is additional to any warranty given by the seller of the Products and does not exclude, limit, restrict or modify the rights and remedies conferred upon the enduser, or the liabilities imposed on the seller, by any statute or other laws in respect of the sale of the Product.



**BELL**  
Flow Systems



**MACNAUGHT**<sup>®</sup>



Quality System



Quality Endorsed Company

ISO 9001 Lic 8602  
Standards Australia

[www.bellflowsystems.co.uk](http://www.bellflowsystems.co.uk)