

positive displacement flow meters

M05 – 1/8” pulse meters

The M05 is a small capacity meter in the M-SERIES™ range and is differentiated by its flow rate capabilities. It has the ability to handle a wide range of fluid viscosities with exceptional levels of repeatability and durability.

Features

- Very compact size.
- Low flow capability with high resolution output.
- Meter accuracy is verified by a factory calibration check after which an individual metrology report is issued.
- Solid state Hall Effect Sensor/Reed Combination.
- Low pressure drop allows for economical pump selection or gravity flow applications.
- Meter design minimises the number of wearable and replaceable parts and extends product life.
- Has IP54/NEMA13 protection.
- Flexibility of installation options (e.g. can be mounted horizontally or vertically; no flow conditioning required).



MR100



M05ASP-X

Specification:

MODEL	M05SSP-X	M05ASP-X
Meter Type	Pulse	Pulse
Meter Body Material	316 Stainless Steel	Aluminium / PPS
Wetted Components:		
Rotor Material	316 Stainless Steel / Ceramic	316 Stainless Steel / Bronze
Shafts	316 Stainless Steel	316 Stainless Steel
O'ring	FKM	FKM
Flow Rate Ranges (Litres Per Hour/US Gallons Per Hour)		
Above 5 cPs	0.5 To 50 / 0.13 To 13.2	0.5 To 50 / 0.13 To 13.2
Below 5 cPs	2 To 50 / 0.53 To 13.2 (Excluding Water)	2 To 50 / 0.53 To 13.2
Accuracy- Within (Of Reading)	+/- 1%	+/- 1%
Repeatability	0.03%	0.03%
Maximum Viscosity	1000 Centipoise	1000 Centipoise
Maximum Operating Pressure	1000kpa/ 150psi/ 10bar "1" 5500kpa/ 800psi/ 55bar	500kpa/ 75psi/ 5bar
Pulsar Type	Dual Hall Effect Sensor/ Reed Switch	Dual Hall Effect Sensor/ Reed Switch
Pulses Per Litre/US Gallon	1547 / 5855.4	1547 / 5855.4
Model Dimensions		
Meter Body	50x50mm / 1.97"X1.97"	50mm X 50mm/1.97" X 1.97"
Port Face To Face	67mm / 2.64"	60mm / 2.36"
Weight	600g / 21.2oz	310g / 11oz
Max. Operating Temperature	120°C / 248°F	80°C / 176°F
Recommended Mesh	200 Mesh	200 Mesh
Strainer		

X = Port Size To order flowmeter you must replace 'X' with the relevant number.

Meter mounted options = MR100 LCD and or MR150LA (4-20mA - module) or combination of both.

Port Size:

Port Size:	Calibrated In:	Electrical Connections
1 = 1/8" BSP (F) ports	litres	1m/39" pulser fly lead (5 core cable)
2 = 1/8" NPT (F) ports	US gallons	1m/39" pulser fly lead (5 core cable)

PPS = Polyphenylene Sulfide Resins

Note: Water usage is limited due to poor lubricating quality of the fluid limiting accuracy and bottom end stable operation.

M05 – 1/8” pulse meters

Options and accessories

M05 - 1/8” Pulse Meters	M05SSP-X	M05ASP-X
FKM O-Ring	●	●
FFPM Elastomer	○	○
EPDM O-Ring	○	○
High Temp Rotors	-	-
High Viscosity Rotors	-	-
Hall Effect Sensor	●	●
Reed Switch	●	●
Solvent Kit	-	-
PPS Rotors With Hastalloy C Shafts	-	-
Remote Mounted LC Display	+	+
4-20ma Module (Remote)	+	+
Meter Mounted LC Display	+	+
Meter Mounted 4-20mA Module	+	+

● Standard ○ Optional - Not Available + Accessory

Dimensions

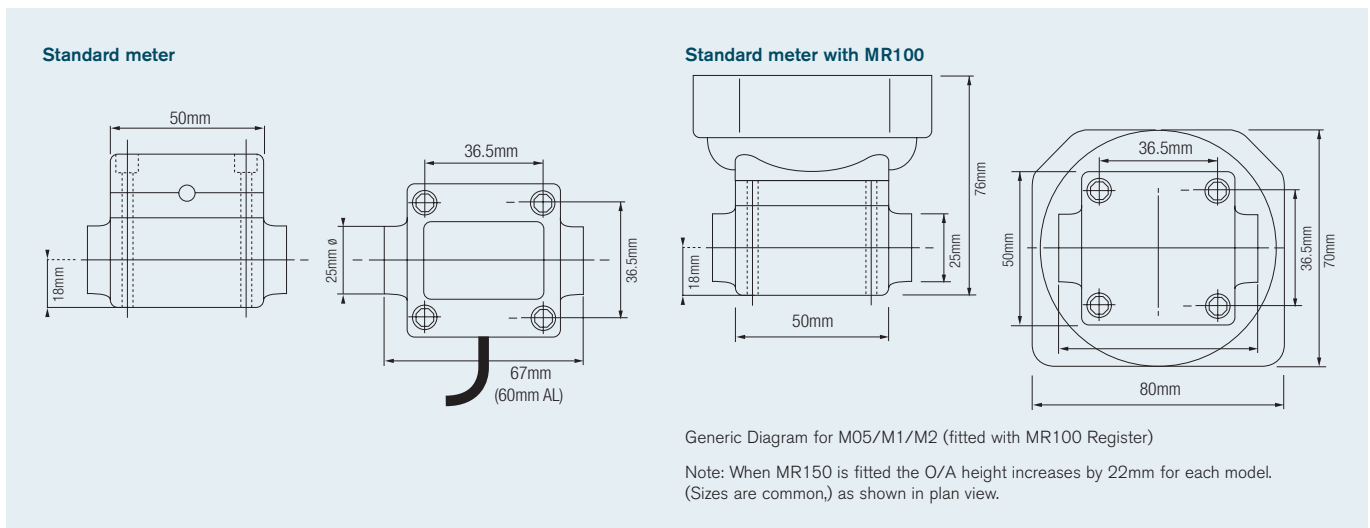

Bell Flow Systems Ltd

7 Swan Business Centre - Osier Way
Buckingham - England - MK18 1TB

☎: +44 (0)1280 817304

☎: +44 (0)1280 817185

✉: sales@bellflowsystems.co.uk

🌐 www.bellflowsystems.co.uk