

Industrial Gas Meter G65

Exact measurement and security



Overview

The gas meter G65 is designed for measurement of gas supplied to industrial plants where maximum consumption of gas is equivalent to 100m³/h of air of density of 1,2 kg/m³.

The gas meters can be used for measurement of:

- Natural gas
- City gas
- Propane-butane gas

Gas meter in standard version is equipped with pulse magnet. Pulse transmitter (1 imp = 0,1m³) can be added at any time.



Technical Data

Maximum flow rate:	Q _{max} = 100 m ³ /h
Minimum flow rate:	Q _{min} = 0,65 m ³ /h
Nominal flow rate:	Q _n = 65 m ³ /h
Cyclic volume:	V = 65 dm ³
Max. working pressure:	P _{max} = 0,2 bar
Index max indication	99999,999 m ³
Starting flow rate:	32 dm ³ /h
Weight:	90 kg

Dimensions

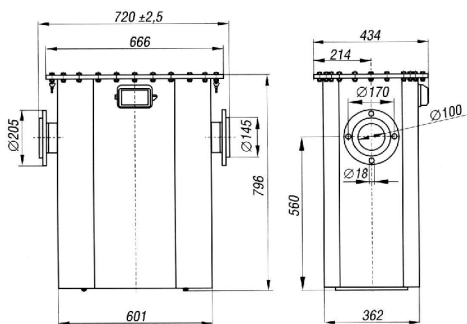

Pressure loss curves

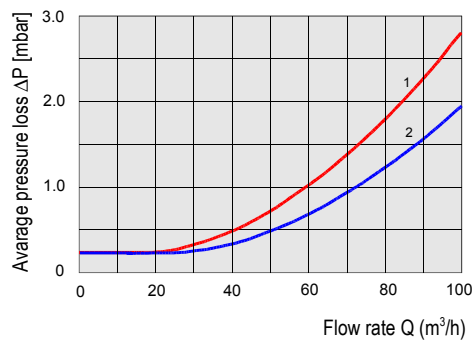

- 1 – air
2 – natural gas

Typical error curves

