



Small screwed unit



Medium screwed unit



Small flanged unit



Medium flanged unit



3" flanged unit

Flow rate indicators with switches.

These units are manufactured in a wide range of sizes and specification options but all have the same basic function.

A dial and mechanical indicator continuously monitor the flow rate at any given time whilst electrical switches can be specified to signal when a particular level has been reached during increasing or decreasing flow rates. Switches are field adjustable over the full range. Where batching, trending, totalising or recording is required, all of our units can be supplied with a 0-10V or 4-20mA output. All sizes are manufactured to the same simple design concept, the main characteristic of which ensures that the pressure drops are confined to an absolute minimum (see 'pressure drop' charts) across the vane orifice at full flow, with viscosities as high as 600cS. Sizes are defined by pipe size and / or maximum flow capacity, and every flow switch is individually calibrated so that full scale deflection is used in each application i.e. the maximum scale reading coincides with the maximum requirement of system as specified by the customer. Calibration may be in any units with single or dual scale to specification.

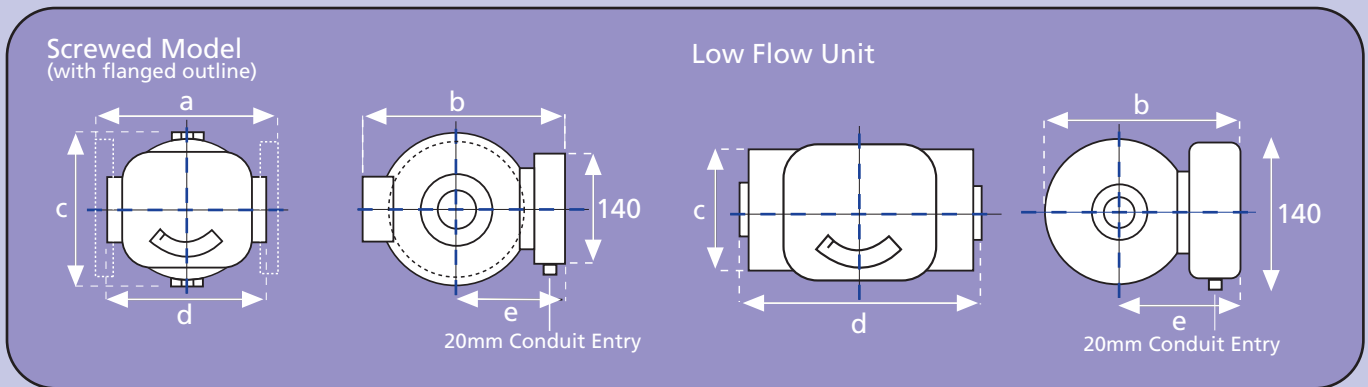

Min Full Scale Flow LPM	Max Full Scale Flow LPM	Pipe Size	Overall Dimensions (mm)					Approximate Weight (kg)				
			a	b	c	d	e	AL	B	CI	S-SS	PVC
0.2 <small>(low flow unit)</small>	5 <small>(low flow unit)</small>	1/4 - 1"	n/a	155	100	188	110	3	8	-	8	3
4	70	1/4 - 1"	160	150	80	130	110	1	2	2	2	1
40	500	3/4 - 2"	180	200	120	150	115	3	7	7	7	3
50	800	2 1/2"	180	200	120	230*	115	5	10	10	10	4
250	1500	3"	255	320	250	305*	160	20	54	50	54	15
300	2000	4"	255	320	250	305*	160	23	60	56	60	17
800	3500	6"	460	500	370	510*	280	60	200	175	200	n/a
1000	5000	8"	485	500	370	535*	280	68	225	200	225	n/a

*Obtained by mating flanges.

FML300**B****LP****3EE****1cS****16F10****S3****D1****SERIES AND FLOW RATE**

FMC* = Low Flow
 FML* = Litres / Min
 FMB* = Imp. Gallons / Min
 FMG* = U.S. Gallons / Min
 FMM* = M3/ Hour
 *Add Full Flow Rate in Units

MATERIAL OF MANUFACTURE

AL = Aluminum
 B = Bronze
 CI = Cast Iron
 CIK = Cast Iron Nickel Plated
 S = Carbon Steel
 SS = Stainless Steel
 PTFE* = PTFE
 PVC* = PVC

*Only available up to 4" Port Connections and 100 psi / 7 bar maximum pressure.

Note: For materials and pressures not specified, please consult factory.

PRESSURE RATING

LP = 300 psi / 20 bar maximum
 MP = 750 psi / 50 bar maximum
 HP = 3000 psi / 200 bar maximum*

*CI, CIK, S & SS only

INDICATOR READ OUT

ME = Mechanical Pointer only
 3EE = SPDT 3 Wire Switch
 3EEG = SPDT 3 Wire Switch with Gold Contacts
 3EE(ATEX3) = SPDT Explosion Proof Micro Switch to ATEX zone 3
 3EE(ATEX2) = SPDT Explosion Proof Switch to ATEX zone 2
 6EE(ATEX2) = DPDT Explosion Proof Switch to ATEX zone 2
 AIR = Pneumatic Switch
 POT = Potentiometer (Specify Rating)
 OUT = 4-20 mAmp Output
 TOT = Digital Rate Totaliser
 TOTX = Digital Rate Totaliser (ATEX)

Note 1: All electrical boxes (apart from TOT & TOTX) also carry a Mechanical Pointer

Note 2: For 4 & 6 Wire Switches replace 3EE by 4EE or 6EE

Note 3: Manufactured to IP65 (NEMA 4) as standard (up to 2 1/2")

ELECTRICAL OPTIONS**CODE: 3EE**

Basic single pole, double throw, 3 wire switch.
 15 Amp - 125, 250 or 480V.AC
 0.5 Amp - 125V.DC / 0.25 Amp - 250V.DC

CODE: 4EE

Contact arrangements is single-pole, double throw, double-break.
 10 Amp - 125 or 250V.AC
 0.3 Amp - 125V.DC / 0.15 Amp - 250V.DC

CODE: 6EE

Double-pole, double throw switches simultaneously make and break two independent circuits.
 10 Amp - 125 or 250V.AC
 0.3 Amp - 125V.DC / 0.15 Amp - 250V.DC

CODE: AIR

This system offers an alternative safety arrangement for operation in explosive atmospheres. Compressed air can be used to transmit an on / off signal from the danger area, or to operate a klaxon inside the danger area.

CODE: POT

Remote read-out option (0-10V). Rating to customer's specification, e.g. 1K, 2K etc.

CODE: OUT

A transducer can be connected to the potentiometer to give the required 4-20 mAmp readout. Data Loggers or Recorders can be added to the system.

The 3 and 6 wire switches described above are available in ATEX approved explosion proof versions, with the appropriate enclosure box. When two or more switches are assembled in one unit, they remain independently adjustable. Re-adjustments may be carried out in the field.

FLOW DIRECTIONS

D1 = → D2 = ←
 D3 = ↑ D4 = ↓

'O' RING SEAL MATERIAL

S1 = Buna (-40°C +110°C)
 S2 = EPDM (-40°C +150°C)
 S3 = Viton (-20°C +200°C)
 S4 = PTFE (-100°C +250°C)
 S5 = Perlast (-15°C +330°C)

PORT CONNECTIONS

2 = 1/4"
 4 = 1/2"
 6 = 3/4"
 8 = 1"
 10 = 1 1/4"
 12 = 1 1/2"
 16 = 2"

Sizes 1/4" - 2" are Screwed or Flanged.

For Flanged Bodies, add relevant code letters (shown below).

20 = 2 1/2"
 24 = 3"
 32 = 4"
 48 = 6"
 64 = 8"

Sizes 2 1/2" - 8". Standard units have Flanged Bodies - add relevant code letters (shown below).

Cast Iron and Steel mating flanges are available:

For Screwed, add - S
 For Socket Weld, add - SW

Standard Threads are BSP, for NPT add - N

For Flanged Connections add one of the following codes:

F10 (PN10)
 F16 (PN16)
 F25 (PN16)
 F40 (PN40)

Alternative Pressure Ratings in BS4504 / DIN2632-5

F150 (ANSI 150)
 F300 (ANSI 300)
 F600 (ANSI 600)

Alternative Pressure Ratings in BS1560 / ANSI B16.5

FAD
 FE
 FF

Alternative Pressure Ratings in BS10

For special flange connections, please enquire at factory

VISCOSITY AT OPERATING TEMPERATURE

State units and scale

eg. Water is 1 Centistoke (cS)

Maximum rating should not exceed 600cS

Air & Gas Applications

Our flow switches can also be used to measure gas flows in exactly the same way as liquid flows. When enquiring for such an application the following information will be required:

Specific gravity of the gas
 Maximum flow volume
 Operating temperature
 Operating pressure



Variable Orifice / Swing Vane Principle

The flow switch body houses a spring-loaded valve plate (vane) which pivots off-centre in a hemispherical cavity. Thus the vane and cavity have a variable area orifice relationship. This gives both a high flow range and a linear relationship between flow rate and vane displacement. The vane indirectly operates both the indicating needle and an adjustable cam, which in turn triggers the micro-switch at any chosen setting of flow rate. Two switches can be supplied to provide high and low (or 'low-low') flow switching.

PRINCIPLE FEATURES & BENEFITS

- All metal construction - no tubes of glass or plastic to break.
- Spring loaded mechanical design - requires no straight pipe run and not affected by orientation.
- Limited movement on internal parts - minimal wear and down time.
- Modular design - reduces maintenance costs, down time, and production loss.
- Direct indication & field adjustable switch(es) - monitors critical flows and provides alarm(s).
- 1% of rate repeatable switch set point - accurate & reliable through all operation cycles.
- Weatherproof enclosure box to IP65 (Nema 4).
- Flow through design - minimal pressure loss.
- Individually calibrated to customer specification - ensures accuracy.
- Adjustable under operating conditions.
- Scale is in units (e.g litres/minute).
- Large range of body materials available.
- Size range from 8mm (1/4") to 200mm (8").
- May be installed in any position.
- Orientation of enclosure box easily changed.
- High switch rating - 10 to 15 Amps.
- ATEX approved Explosion-proof models available.
- Will pass twice the maximum indicated flow.
- Acts as non-return valve.

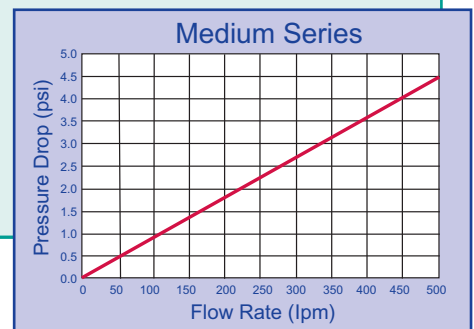
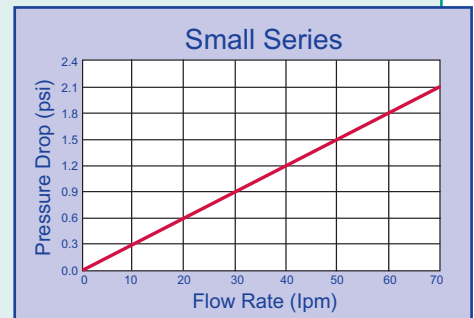

Applications

Water (clean or dirty)
De-mineralised Water
De-ionized Water

Petroleum Based Oils
Synthetic Based Oils
Coolants

Solvents
Paints
Corrosive Fluids

Air & Gases

Low Flow / Piston Style Principle

A fixed tapered needle passing through an orifice in the face of a piston, completely seals the port to port connection when the piston is seated. As flow commences the piston is displaced against a 4 psi differential spring and moves over the tapered section of the needle, thus permitting flow through the orifice. Only the needle taper configuration needs to be changed to accommodate any specified viscosity and maximum flow requirement, thus the full deflection of the unit can be used for all applications.



PRINCIPLE FEATURES & BENEFITS

- Suitable for liquid or gas applications.
- Measures down to 200 cc/minute (at 1cS).
- Measures down to 50 cc/minute (at 20cS or higher).
- Maximum capacity 5 litres/minute.
- Electrical switch(es), and/or calibrated indication.
- 4-20mA and 0-10v outputs available.
- Cannot be switched on cold start-up.
- Suitable for 20, 50 and 200 bar maximum pressures.
- Inline design, 1/4" to 1" BSP or NPT female inlet and outlet.
- May be mounted in any orientation.



Visual Flow Indicator go with the flow...

The 'Rising Ball' and 'Spinner': the latest design of low cost, 'entry level' Flow Indicators. These robust indicators out perform other visual flow instruments by a considerable margin. When calibrated flow indicators are not needed these units will satisfy most requirements within pipe sizes 8mm to 40mm. Being constructed from high quality materials these in-line indicators will meet the needs of many chemical applications, as well as being suitable for water, oil and gases.

Visual flow indicators start to operate once flow has commenced, this can be from as low as 0.1 LPM. The exceptional ratio between maximum and minimum flow is achieved by carefully tolerated manufacture. When operators require a visual confirmation in their pipework, for lubrication and coolant flow, these simple indicators can provide a cost effective solution for plant protection. Including one of these inexpensive fittings to pipework on a power-plant may save thousands of pounds in downtime and bearing or pump impeller replacement. Add to this the safety implications resulting from plant failure and the true benefits may be fully appreciated.

Features & Benefits

- Suitable for water, gas and other clear liquids.
- Excellent chemical compatibility due to the materials of construction
- Operates over a wide flow range.
- Competitively priced.
- Off the shelf deliveries.
- No routine maintenance needed.
- Unrivalled flow and pressure drop performance.
- Manufactured in stainless steel or bronze.

Applications

- This flow indicator is primarily used in plant protection applications to show lubrication or coolant flow to pumps, compressors or engines. Applications include:
- Early warning of overheating, bearing or seal failure.
 - Detecting changes in the colour and condition of liquids during processing.
 - Pump, compressor and diesel protection.
 - Ensuring that flow of cooling water is maintained to specialised welding equipment.
 - Indication of air entrainment.
 - Indicating chemical dosing on water treatment facilities.
 - Showing the presence of condensate in steam return lines.
 - Maintaining demineralised water rinsing essential to electronics components manufacture.

RISING BALL

Figure 1

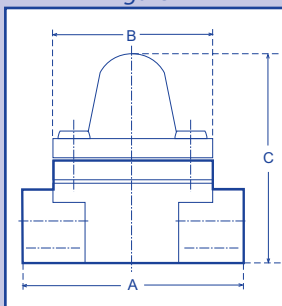

SPINNER

Figure 2

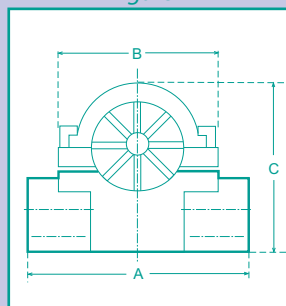

Technical Data

Materials:

Body - Stainless Steel (ANC4B) or - Bronze (LG2)
 Clamp Ring - Stainless Steel or Bronze
 Spinner - PPS plastic, 'canary yellow'
 Ball - PTFE 'Teflon'
 Glass Dome - Annealed Borosilicate
 'O' Ring - Viton (standard), PTFE (optional)
 Gasket - Klingsil (C-4400)
 Fasteners - Stainless Steel

Pressure:

- 16 Bar (maximum working pressure)

Temperature:

- 200°C (maximum working temperature)

Connections:

- BSP(F) parallel and NPT(F) taper

Flow Direction:

- Rising Ball: Horizontally Mounted - Single Direction

- Spinner: Horizontal/Vertical Mounting - Bi-Directional

Every effort will be made to meet any special connections and material requirements.

Table 1

Flow Requirements				Dimensions and Weights					
Size	Min Flow	Out of Socket	Pressure Drop - 2 m/sec	Bore	Size	Weight	'A' Overall Length	'B' Width (Clamp)	'C' Overall Height
mm	l/min	l/min	bar	mm	inch	kg	mm	mm	mm
8	0.1	1.0	0.13	8	1/4	0.72	76	63	79
10	0.1	1.0	0.16	10	3/8	0.69	76	63	79
15	0.1	1.0	0.19	15	1/2	0.65	76	63	79
20	2.4	5.2	0.16	20	3/4	1.30	89	63	95
25	2.7	5.5	0.40	25	1	1.25	89	63	95
32	11.0	16.0	0.20	32	1 1/4	2.50	117	75	125
40	16.0	21.0	0.23	40	1 1/2	2.35	117	75	125

Table 2

Flow Requirements				Dimensions and Weights					
Size	Min Flow	Max flow	Pressure Drop - 2 m/sec	Bore	Size	Weight	'A' Overall Length	'B' Width (Clamp)	'C' Overall Height
mm	l/min	l/min	bar	mm	inch	kg	mm	mm	mm
8	0.7	30	0.14	8	1/4	0.68	76	63	65
10	0.8	40	0.16	10	3/8	0.65	76	63	65
15	1.0	55	0.22	15	1/2	0.62	76	63	65
20	1.2	90	0.19	20	3/4	1.25	89	63	83
25	1.5	140	0.50	25	1	1.20	89	63	83



certificate number: 16168

For further information contact:

Tel: 01296 658 600 Fax: 01296 658 515

Email: sales@bellflowsystems.co.uk www.bellflowsystems.co.uk

Bell Flow Systems Limited, Building 426 Westcott Venture Park
 Westcott, Aylesbury, Bucks HP18 0XB