

Wide Measuring Range
Communication
Easy Reading

Aquadis

Rotary piston volumetric type water meter

- ▶ Class C and D
- ▶ Pre-equipped for communication
- ▶ Very low starting flow

Aquadis is an EEC/ISO Class C and D piston type meter with extra dry register for residential and commercial & industrial applications.

The Technology

Aquadis combines the advantages of piston type technology together with proven reliability of the extra dry register. No gears in contact with water.

The high technology implemented to manufacture measuring chambers ensures stable and durable accuracy of Aquadis meter.

Metrological Performances

- Class C in all positions
- Class D in all positions for DN 15 and Coaxial

Measuring Range

- Very low starting flow allows leakage detection
- Very large measuring range with Qn/Qmin Ratio > 180 (Qn 1.5)

Easy Reading

Aquadis extra dry register combines the following advantages:

- Rotation close to 360° on site
- Large numbered rollers with good contrast for excellent reading capability
- Wiper ensures readability of the extra-dry register in tough humid conditions
- Case protection: IP 68

Communication Device

- Pre-equipped for future communication through Cyble



Working Principle

The Aquadis has two main components; the hydraulics that allows measurement of the water flow and the register that displays the measured water volume.

Transmission interface between those components is achieved by a magnetic coupling ③.

Aquadis is a piston type volumetric meter ①. Each rotation of the piston in the measuring chamber represents a given volume of water passing through.

The magnetic coupling transmission, standard on the Aquadis line, is accompanied by an extra-dry register ②.

Both gears and the register are in a waterproof and air proof enclosure.



► Cyble RF fitted on Aquadis meter



► Register for DN 15 and 20 meters

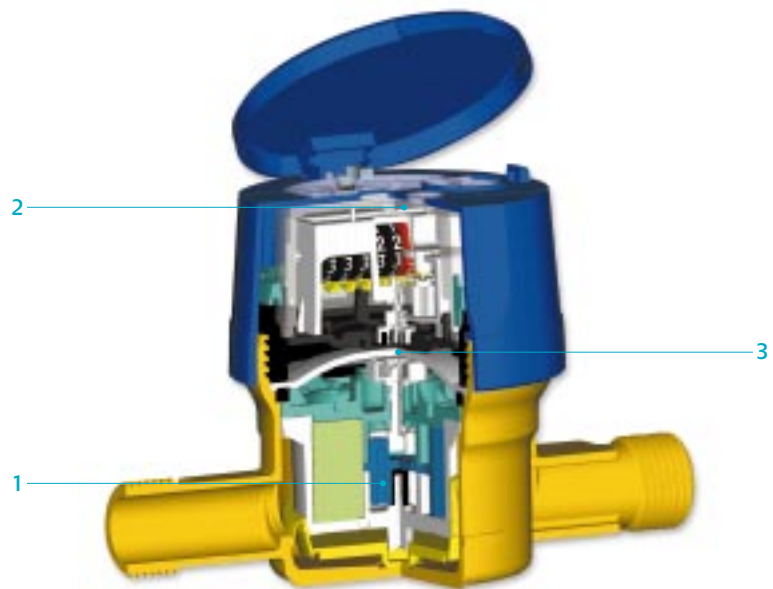

Communication

The Aquadis is supplied pre-equipped with Cyble Target

Allows communication and remote reading through:

- Pulse output (Cyble Sensor)
- M-Bus protocol (Cyble M-Bus)
- Radio frequency wireless link (Cyble RF)

Key Advantages of Cyble Technology

- No need for additional investment on the meter to implement remote reading

- Actaris standardized meter interface, irrespective of meter technology and widely spread on Actaris water meters range
- Reliability brought by electronic switch (no wear or bouncing)
- Reverse flow management
- Principle proven in the field for more than 5 years
- Pre-equipment being immune to magnetic tampering

Metrological Characteristics

Nominal diameter (DN)	mm	15*	20	25	30	40	60/65									
E.E.C. metrology class		Class C all positions														
E.E.C. approval		F99.0.382.003														
Maximum admissible temperature	°C	30														
Maximum temperature for short period	°C	50														
Maximum admissible pressure	bar	16			12											
Testing pressure	bar	25														
Pressure loss group at Qmax	bar	1														
Nominal flow rate	Qn	m³/h	0.75	1	1.5	1.5	2.5	3.5	5	10	20					
Maximum flow rate	Qmax	m³/h	2	2	3	3	5	7	10	20	40					
Minimum flow rate	Qmin	l/h	7.5	10	15	15	25	35	50	100	120					
Transitional flow rate	Qt	l/h	11.25	15	22.5	22.5	37.5	52.5	75	150	300					
Starting flow rate		l/h	1		2		6		11		18	30				
Accuracy ± 5%**		l/h	4		4		4		10		25		25	40	70	
Accuracy ± 2%**		l/h	7		7		7		13		45		50		80	100
Indication range		m³	10 ⁵						10 ⁶							
Minimum scale interval		l	0.05						0.5							
Communication pre-equipment			Cyble Technology													

* Both coaxial and in line, also exists variable QN 0.75 to 1 m³/h and QN 1 to 1.5 m³/h - ** Manufacturing average values

Class D meter - In line DN 15 and Coaxial - According to British standard 5728

Nominal flow rate	Qn	m³/h	1		1.5	
Maximum flow rate	Qmax	m³/h	2		3	
Minimum flow rate	Qmin	l/h	7.5		11.25	
Transitional flow rate	Qt	l/h	11.5		17.25	
Indication range		m³	9 999.9999			
Minimum scale interval		l	0.02			

Pulse Value

	HF Signal	LF Signal (according to K factor for Cyble Sensor Module)					
Meter range		K=1	K=2.5	K=10	K=25	K=100	K=1000
DN 15 to 40*	1 l	1 l	2.5 l	10 l	25 l	100 l	1 m³
DN 60/65	10 l	10 l	25 l	100 l	250 l	1 m³	10 m³

* For sizes 15 and 20 mm, 4/4 register divides by 10 the table values.

Head Loss

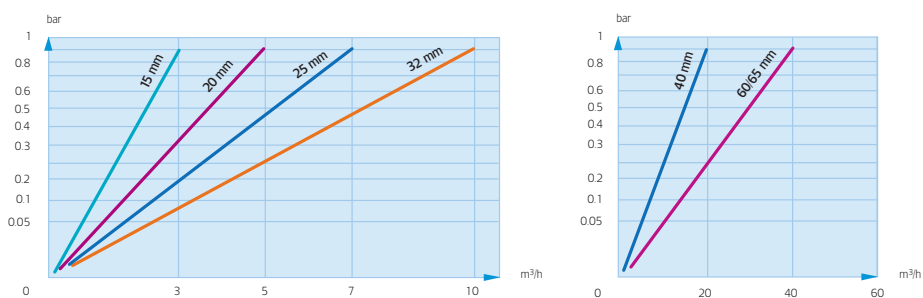

► Coaxial Register DN 15, Class D



► Aquadis Coaxial model

► DN 15-20

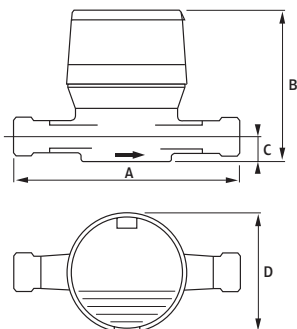

► DN 25-30-40

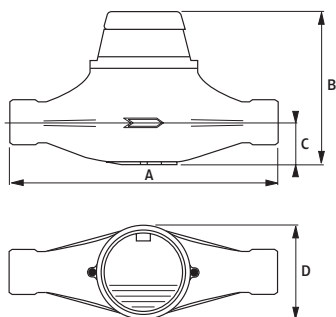

► DN 60/65

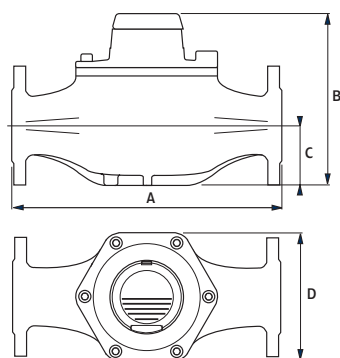

Dimensions

Nominal diameter (DN)	mm	15	20	25	30	40	60/65
Meter thread	inches	G 3/4"	G 1"	G 1" 1/4	G 1" 1/2	G 1"	Flanges
	mm	20x27	26x34	33x42	40x49	50x60	PN 10/16
A	mm	170*	190	260	260	300	420
B	mm	116	143	156	156	176	254
C	mm	20	18	44	44	57	93
D	mm	88	88	110	110	140	202
Weight	kg	1	1.3	2.7	2.8	4.9	22.2

* Other available lengths: 105, 110, 115, 134, 165 mm (G 3/4") and 105, 165, 190 mm (G 1").

► Coaxial DN 15

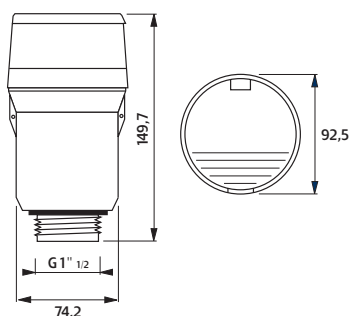

Options (none exhaustive list)

Aquadis meters may be fitted with:

- Non return-valve for outlet pipe DN 15, 20, 25, 30 and 40
- Removable cap for DN 15 and 20
- Equipped with Cyble RF from the factory (please refer to specific leaflet)

For more information, please contact your local agency.



Actaris

9, rue Ampère

71031 Mâcon cedex - France

For more information, see www.actaris.com

tel +33 3 85 29 39 00

fax +33 3 85 29 38 58